



Georgia Standards of Excellence Curriculum Frameworks

Mathematics

GSE Grade 8

Unit 1: Transformations, Congruence, and
Similarity



Richard Woods, Georgia's School Superintendent
"Educating Georgia's Future"

Unit 1
Transformations, Congruence, and Similarity

TABLE OF CONTENTS

OVERVIEW	3
STANDARDS FOR MATHEMATICAL PRACTICE	3
STANDARDS FOR MATHEMATICAL CONTENT	4
BIG IDEAS	4
ESSENTIAL QUESTIONS	5
CONCEPTS/SKILLS TO MAINTAIN	5
FLUENCY	5
STRATEGIES FOR TEACHING AND LEARNING	6
SELECTED TERMS AND SYMBOLS	7
EVIDENCE OF LEARNING	8
FORMATIVE ASSESSMENT LESSONS (FAL)	8
SPOTLIGHT TASKS	9
3-ACT TASKS	9
TASKS	9
• Introduction to Reflections, Translations, and Rotations	11
• Dilations in the Coordinate Plane	18
• Changing Shapes	32
• Coordinating Reflections	38
• Coordinating Translations	46
• Coordinating Rotations	51
• Representing and Combining Transformations	57
• Playing with Dilations	60
• Similar Triangles	69
• Tessellating Triangles	77
• Transversals, Tape, and Stickies!	82
• Lunch Lines	87
• For the Win!	93
• Window “Pain”	98
• Sheldon’s Shelving Suggestions	110
TECHNOLOGY	119

OVERVIEW

In this unit students will:

- develop the concept of transformations and the effects that each type of transformation has on an object;
- explore the relationship between the original figure and its image in regards to their corresponding parts being moved an equal distance which leads to concept of congruence of figures;
- learn to describe transformations with both words and numbers;
- relate rigid motions to the concept of symmetry and to use them to prove congruence or similarity of two figures;
- physically manipulate figures to discover properties of similar and congruent figures; and focus on the sum of the angles of a triangle and use it to find the measures of angles formed by transversals (especially with parallel lines), find the measures of exterior angles of triangles, and to informally prove congruence.

Although the units in this instructional framework emphasize key standards and big ideas at specific times of the year, routine topics such as estimation, mental computation, and basic computation facts should be addressed on an ongoing basis. Ideas related to the eight Standards for Mathematical Practice should be addressed constantly as well. To assure that this unit is taught with the appropriate emphasis, depth, and rigor, it is important that the tasks listed under “Evidence of Learning” be reviewed early in the planning process. A variety of resources should be utilized to supplement this unit. This unit provides much needed content information, but excellent learning activities as well. The tasks in this unit illustrate the types of learning activities that should be utilized from a variety of sources.

STANDARDS FOR MATHEMATICAL PRACTICE

Refer to the Comprehensive Course Overview for more detailed information about the Standards for Mathematical Practice.

1. Make sense of problems and persevere in solving them.
2. Reason abstractly and quantitatively.
3. Construct viable arguments and critique the reasoning of others.
4. Model with mathematics.
5. Use appropriate tools strategically.
6. Attend to precision.
7. Look for and make use of structure.
8. Look for and express regularity in repeated reasoning.

Mathematical standards are interwoven and should be addressed throughout the year in as many different units and activities as possible in order to emphasize the natural connections that exist among mathematical topics.

STANDARDS FOR MATHEMATICAL CONTENT

Understand congruence and similarity using physical models, transparencies, or geometry software.

MGSE8.G.1 Verify experimentally the congruence properties of rotations, reflections, and translations: lines are taken to lines and line segments to line segments of the same length; angles are taken to angles of the same measure; parallel lines are taken to parallel lines.

MGSE8.G.2 Understand that a two-dimensional figure is congruent to another if the second can be obtained from the first by a sequence of rotations, reflections, and translations; given two congruent figures, describe a sequence that exhibits the congruence between them.

MGSE8.G.3 Describe the effect of dilations, translations, rotations, and reflections on two-dimensional figures using coordinates.

MGSE8.G.4 Understand that a two-dimensional figure is similar to another if the second can be obtained from the first by a sequence of rotations, reflections, translations, and dilations; given two similar two-dimensional figures, describe a sequence that exhibits the similarity between them.

MGSE8.G.5 Use informal arguments to establish facts about the angle sum and exterior angle of triangles, about the angles created when parallel lines are cut by a transversal, and the angle-angle criterion for similarity of triangles. *For example, arrange three copies of the same triangle so that the three angles appear to form a line, and give an argument in terms of transversals why this is so.*

BIG IDEAS

- What makes shapes alike and different can be determined by geometric properties.
- Shapes can be described in terms of their location in a plane or in space. Coordinate systems can be used to describe these locations precisely.
- Shapes can be moved in a plane or in space to make congruent or similar shapes.
- Movements of shapes in a plane or in space are called transformations and include translations, reflections, rotations, and dilations.
- Reflections, translations, and rotations are *actions* that produce congruent geometric objects.
- A dilation is a transformation that changes the size of a figure, but not the shape.
- When parallel lines are cut by a transversal, corresponding, alternate interior and alternate exterior angles are congruent.

ESSENTIAL QUESTIONS

- How can the coordinate plane help me understand properties of reflections, translations, and rotations?
- What is the relationship between reflections, translations, and rotations?
- What is a dilation and how does this transformation affect a figure in the coordinate plane?
- How can I tell if two figures are similar?
- In what ways can I represent the relationships that exist between similar figures using the scale factors, length ratios, and area ratios?
- What strategies can I use to determine missing side lengths and areas of similar figures?
- Under what conditions are similar figures congruent?
- When I draw a transversal through parallel lines, what are the special angle and segment relationships that occur?
- Why do I always get a special angle relationship when any two lines intersect?
- How can I be certain whether lines are parallel, perpendicular, or skew lines?

CONCEPTS/SKILLS TO MAINTAIN

It is expected that students will have prior knowledge/experience related to the concepts and skills identified below. It may be necessary to pre-assess in order to determine if time needs to be spent on conceptual activities that help students develop a deeper understanding of these ideas.

- plotting on the coordinate plane
- angle measurement
- characteristics of 2-D and 3-D shapes
- solving equations
- operations with fractions and decimals

FLUENCY

It is expected that students will continue to develop and practice strategies to build their capacity to become fluent in mathematics and mathematics computation. The eventual goal is automaticity with math facts. This automaticity is built within each student through strategy development and practice. The following section is presented in order to develop a common understanding of the ideas and terminology regarding fluency and automaticity in mathematics:

Fluency: Procedural fluency is defined as skill in carrying out procedures flexibly, accurately, efficiently, and appropriately. Fluent problem solving does not necessarily mean solving

problems within a certain time limit, though there are reasonable limits on how long computation should take. Fluency is based on a deep understanding of quantity and number.

Deep Understanding: Teachers teach more than simply “how to get the answer” and instead support students’ ability to access concepts from a number of perspectives. Therefore students are able to see math as more than a set of mnemonics or discrete procedures. Students demonstrate deep conceptual understanding of foundational mathematics concepts by applying them to new situations, as well as writing and speaking about their understanding.

Memorization: The rapid recall of arithmetic facts or mathematical procedures. Memorization is often confused with fluency. Fluency implies a much richer kind of mathematical knowledge and experience.

Number Sense: Students consider the context of a problem, look at the numbers in a problem, make a decision about which strategy would be most efficient in each particular problem.

Number sense is not a deep understanding of a single strategy, but rather the ability to think flexibly between a variety of strategies in context.

Fluent students:

- flexibly use a combination of deep understanding, number sense, and memorization.
- are fluent in the necessary baseline functions in mathematics so that they are able to spend their thinking and processing time unpacking problems and making meaning from them.
- are able to articulate their reasoning.
- find solutions through a number of different paths.

For more about fluency, see: <http://www.youcubed.org/wp-content/uploads/2015/03/FluencyWithoutFear-2015.pdf> and: <http://joboaler.com/timed-tests-and-the-development-of-math-anxiety/>

STRATEGIES FOR TEACHING AND LEARNING

- Students should be actively engaged by developing their own understanding.
- Mathematics should be represented in as many ways as possible by using graphs, tables, pictures, symbols and words.
- Interdisciplinary and cross curricular strategies should be used to reinforce and extend the learning activities.
- Appropriate manipulatives and technology should be used to enhance student learning.
- Students should be given opportunities to revise their work based on teacher feedback, peer feedback, and metacognition which includes self-assessment and reflection.
- Students should write about the mathematical ideas and concepts they are learning.
- Consideration of all students should be made during the planning and instruction of this unit.
- Teachers need to consider the following:
 - What level of support do my struggling students need in order to be successful with this unit?

- In what way can I deepen the understanding of those students who are competent in this unit?
- What real life connections can I use in my lessons that will help my students utilize the skills practiced in this unit?

SELECTED TERMS AND SYMBOLS

The following terms and symbols are often misunderstood. These concepts are not an inclusive list and should not be taught in isolation. However, due to evidence of frequent difficulty and misunderstanding associated with these concepts, instructors should pay particular attention to them and how their students are able to explain and apply them.

Students should explore these concepts using models and real life examples. Students should understand the concepts involved and be able to recognize and/or demonstrate them with words, models, pictures, or numbers.

The websites below are interactive and include a math glossary suitable for middle school students. **Note – Different sources use different definitions. Please preview any website for alignment to the definitions given in the frameworks.**

Visit <http://intermath.coe.uga.edu> or <http://mathworld.wolfram.com> to see additional definitions and specific examples of many terms and symbols used in grade 8 mathematics.

- [Alternate Exterior Angles](#)
- [Alternate Interior Angles](#)
- [Angle of Rotation](#)
- [Congruent Figures](#)
- [Corresponding Sides](#)
- [Corresponding Angles](#)
- [Dilation](#)
- [Linear Pair](#)
- [Reflection](#)
- [Reflection Line](#)
- [Rotation](#)
- [Same-Side Interior Angles](#)
- [Same-Side Exterior Angles](#)
- [Scale Factor](#)

- [Similar Figures](#)
- [Transformation](#)
- [Translation](#)
- [Transversal](#)

EVIDENCE OF LEARNING

By the conclusion of this unit, students should be able to demonstrate the following competencies:

- use compasses, protractors, and rulers or technology to explore figures created from translations, reflections, and rotations and understand that these transformations produce images of exactly the same size and shape as the pre-image and are known as rigid transformations;
- examine two figures to determine congruency by identifying the rigid transformation(s) that produced the figures and write statements of congruency;
- identify resulting coordinates from translations, reflections, and rotations, recognizing the relationship between the coordinates and the transformation. Additionally, students recognize the relationship between the coordinates of the pre-image, the image and the scale factor following a dilation from the origin;
- understand similar figures have angles with the same measure and sides that are proportional and understand that a scale factor greater than one will produce an enlargement in the figure, while a scale factor less than one will produce a reduction in size; and
- use exploration and deductive reasoning to determine relationships that exist between a) angle sums and exterior angle sums of triangles, b) angles created when parallel lines are cut by a transversal, and c) the angle-angle criterion for similarity of triangle. Also, students should be able to use deductive reasoning to find the measure of missing angles.

FORMATIVE ASSESSMENT LESSONS (FAL)

Formative Assessment Lessons are intended to support teachers in formative assessment. They reveal and develop students' understanding of key mathematical ideas and applications. These lessons enable teachers and students to monitor in more detail their progress towards the targets of the standards. They assess students' understanding of important concepts and problem solving performance, and help teachers and their students to work effectively together to move each student's mathematical reasoning forward.

More information on Formative Assessment Lessons may be found in the Comprehensive Course Guide.

SPOTLIGHT TASKS

For Middle and High Schools, each Georgia Standards of Excellence mathematics unit includes at least one Spotlight Task. The Spotlight Tasks serve as exemplars for the use of the Standards for Mathematical Practice, appropriate unit-level Georgia Standards of Excellence, and research-based pedagogical strategies for instruction and engagement. Each task includes teacher commentary and support for classroom implementation. Some of the Spotlight Tasks are revisions of existing Georgia tasks and some are newly created. Additionally, some of the Spotlight Tasks are 3-Act Tasks based on 3-Act Problems from Dan Meyer and Problem-Based Learning from Robert Kaplinsky.

3-ACT TASKS

A Three-Act Task is a whole group mathematics task consisting of 3 distinct parts: an engaging and perplexing Act One, an information and solution seeking Act Two, and a solution discussion and solution revealing Act Three.

More information along with guidelines for 3-Act Tasks may be found in the Comprehensive Course Guide.

TASKS

Task Name	Task Type <i>Grouping Strategy</i>	Content Addressed	Standard(s)
<u>Introduction To Reflections and Rotations</u>	Performance Task <i>Individual/Partner/Small Group</i>	Recognize/describe a reflection, translation, and rotation.	MGSE8.G.1
<u>Dilations In The Coordinate Plane</u>	Learning Task <i>Individual/Partner/Small Group</i>	Find rules to describe transformations.	MGSE8.G.2 MGSE8.G.3 MGSE8.G.4
<u>Changing Shapes</u>	Performance Task <i>Individual/Partner/Small Group</i>	Identify effects of transforming by a rule.	MGSE8.G.3 MGSE8.G.4
<u>Coordinating Reflections</u>	Learning Task <i>Individual/Partner/Small Group</i>	Develop a formal definition for reflection.	MGSE8.G.3
<u>Coordinating Translations</u>	Learning Task <i>Individual/Partner/Small Group</i>	Develop a formal definition for translation.	MGSE8.G.3
<u>Coordinating Rotations</u>	Learning Task <i>Individual/Partner/Small Group</i>	Develop a formal definition for rotation.	MGSE8.G.3

Georgia Department of Education
 Georgia Standards of Excellence Framework
GSE Grade 8 • Unit 1

<u>Representing and Combining Transformations (FAL)</u>	Formative Assessment Lesson <i>Partner/Small Group</i>	Practice using transformations.	MGSE8.G.2
<u>Playing With Dilations</u>	Performance Task <i>Individual/Partner/Small Group</i>	Investigate the effects of dilation.	MGSE8.G.4
<u>Similar Triangles</u>	Learning Task <i>Individual/Partner/Small Group</i>	Discover the relationships that exist between similar figures.	MGSE8.G.4 MGSE8.G.5
<u>Tessellating Triangles (Spotlight Task)</u>	Learning Task <i>Individual/Partner/Small Group</i>	Exploring angle sum and exterior angle of triangles through tessellations	MGSE8.G.5
<u>Transversals, Tape and Stickies!</u>	Learning Task <i>Partner/Small Group</i>	Build & reinforce understandings of angle relationships of intersecting and parallel/transversal lines.	MGSE8.G.5
<u>Lunch Lines</u>	Performance Task <i>Individual/Partner/Small Group</i>	Reinforce understanding of angle relationships of intersecting and parallel/transversal lines.	MGSE8.G.5
<u>For the Win! (Spotlight Task)</u>	Performance Task <i>Individual/Partner/Small Group</i>	Reinforce understanding of angle relationships of intersecting and parallel/transversal lines.	MGSE8.G.5
<u>Window Pain</u>	Performance Task <i>Individual/Partner/Small Group</i>	Reinforce understanding of angle relationships of intersecting and parallel/transversal lines.	MGSE8.G.5
<u>Culminating Task: Sheldon's Shelving Suggestions</u>	Culminating Task <i>Individual/Partner/Small Group</i>	Reinforce understanding of angle relationships of intersecting and parallel/transversal lines.	MGSE8.G.2 MGSE8.G.4 MGSE8.G.5
<u>Technology Resources</u>			

Introduction To Reflections, Translations, And Rotations

[Back to Task Table](#)

In this task students will recognize/describe a reflection, translation, and rotation.

STANDARDS FOR MATHEMATICAL CONTENT

MGSE8.G.1 Verify experimentally the congruence properties of rotations, reflections, and translations: lines are taken to lines and line segments to line segments of the same length; angles are taken to angles of the same measure; parallel lines are taken to parallel lines.

STANDARDS FOR MATHEMATICAL PRACTICE:

This task uses all of the practices with emphasis on:

1. Make sense of problems and persevere in solving them.
4. Model with mathematics.
5. Use appropriate tools strategically.
6. Attend to precision.
7. Look for and make use of structure.
8. Look for and express regularity in repeated reasoning.

BACKGROUND KNOWLEDGE/TEACHER NOTES:

The initial struggle students have with transformations is plotting points correctly on the coordinate plane (see common misconceptions below). This idea was first introduced to students in 5th grade, and should be reviewed with students prior to this task.

It may be helpful to open a discussion with students regarding the new vocabulary: reflections, translations, and rotations. Find out what students know about these terms before beginning this task in order to get an idea of their understandings as the unit begins.

In order for students to be successful, students should be confident in their understandings of the following standards:

[MGSE5.G.1](#) [MGSE5.G.2](#) [MGSE6.G.3](#) [MGSE7.G.1](#)

COMMON MISCONCEPTIONS:

The following misconceptions are common among middle school students engaged in this unit:

- *Some students will continue to mix up the x and y axis.*
- *Students often will confuse “rules” for finding coordinates for rotations, translations, and reflections.*
- *Students often mis-label corresponding parts of congruent and/or similar figures on the coordinate plane.*

- *Students will need multiple opportunities to explore the transformation of figures in order to make sense of the patterns between the coordinates of the original and the transformed figure.*

In order to prevent or correct these misconceptions, any rules students use to determine coordinates for any transformation, should be determined by the students. This can be done through discovery in many of the tasks within this unit. When students make sense of these ideas, discover patterns for each of the three transformations, and discuss them with their peers, they will be less likely to develop these misconceptions and even correct some of them if they already exist. This saves the time of having to reteach much of these concepts again later.

ESSENTIAL QUESTIONS:

- How can the coordinate plane help me understand properties of reflections, translations and rotations?
- What is the relationship between reflections, translations and rotations?

MATERIALS:

- Graph paper
- Computer or computer lab (optional)

GROUPING:

- *Individual/Partner/Small Group*

TASK DESCRIPTION, DEVELOPMENT AND DISCUSSION:

Teachers may want to introduce their students to transformation using computer applets if they have access. The activities at the National Library of Virtual Manipulatives offer opportunities for students to experiment with various transformations.

REFLECTIONS

Have students visit the National Library of Virtual Manipulatives to explore and describe properties of reflection. Use the manipulative named, 9-12 Geometry “Transformations-Reflections” and click on “Activities” to access the following:

- Playing with Reflections
- Hitting the Target
- Describing Reflection

Direct Link: http://nlvm.usu.edu/en/nav/frames_asid_298_g_4_t_3.html?open=activities

Home Page: <http://nlvm.usu.edu/en/nav/vlibrary.html>

The introduction to reflections using this website may be done as a whole group with a projector or in a computer lab individually or in pairs. After students explore with the applet, they should be prompted to check the “Axes” boxes and make observations about the coordinates of the vertices of objects and their reflected images. Students can move the line of reflection on top of either the horizontal or vertical axes. If the students work on the tasks as individuals or in pairs, prepare a list of questions for them to answer while exploring the website, such as “What happens to a shape as the reflection line is moved?” or “What happens when a shape is positioned so that is intersected by a line of reflection?” Teachers should also prompt students to justify their answers to the questions provided on the site.

At the end of this session, whether the activity is done as a whole group, individually, or in pairs, students should report to the whole class what they have learned. The purpose of these activities is to provoke class discussion.

TRANSLATIONS

Have students visit the [National Library of Virtual Manipulatives](#) to explore and describe properties of translations. Use the manipulative named, 9-12 Geometry “Transformations-Translations” and click on “Activities” to access the following:

- Playing with Translations
- Hitting the Target
- Describing Translations.

Direct Link: http://nlvm.usu.edu/en/nav/frames_asid_302_g_4_t_3.html?open=activities

Home Page: <http://nlvm.usu.edu/en/nav/vlibrary.html>

The introduction to translations using this website may be done as a whole group with a projector or in a computer lab individually or in pairs. If the students work on the tasks as individuals or in pairs, prepare a list of questions for them to answer while exploring the website. For example, “What affects the location of the translated image?” “What patterns do you notice in the coordinates of the vertices when a polygon has a horizontal translation?” and “What would happen if you connect the corresponding vertices of the origin polygon and its image?” At the end of this session, whether the activity is done as a whole group, individually, or in pairs, students should report to the whole class what they have learned.

Teachers should offer guiding questions or prompt discussion of the parallel lines that are imbedded in translations of polygons (a side and its translated image are parallel to one another; the translation vectors of each vertex are also parallel to one another). Teachers may choose to introduce the term vector however students are not expected to formally know these terms until later in the curriculum.

ROTATIONS

Have students visit the [National Library of Virtual Manipulatives](http://nlvm.usu.edu/en/nav/frames_asid_300_g_4_t_3.html?open=activities) to explore and describe properties of rotation. Use the manipulative named, 9-12 Geometry “Transformations-Rotations” and click on “Activities” to access the following:

- Playing with Rotations
- Hitting a Target
- Describing Rotations

Direct Link: http://nlvm.usu.edu/en/nav/frames_asid_300_g_4_t_3.html?open=activities

Home Page: <http://nlvm.usu.edu/en/nav/vlibrary.html>

The introduction to rotations using this website may be done as a whole group with a projector or in a computer lab individually or in pairs. If the students work on the tasks as individuals or in pairs, prepare a list of questions for them to answer while exploring the web site. For example, “What determines the location of the image of a rotation?” or “If a rectangle is rotated 90 degrees counterclockwise, what happens to the coordinates of its vertices?” At the end of this session, whether the activity is done as a whole group, individually, or in pairs, students should report to the whole class what they have learned.

Teachers familiar with Geometer’s Sketchpad may also choose to utilize many published activities that will introduce transformations to their students.

Teachers may also choose to investigate the TransmoGrapher 2 at Interactivate Activities:
<http://www.shodor.org/interactivate/activities/transform2/index.html>

DIFFERENTIATION:

Extension:

- See note regarding Geometer’s Sketchpad & TransmoGrapher2

Intervention/Scaffolding:

- You may need to work through problems 1 & 2 with the class, and then have the students do problem 3 on their own or with a partner. Prompt struggling students by asking guiding questions.

Introduction To Reflections, Translations, And Rotations

1. On your graph paper draw and label a square. Describe its original position and size.

Answers will vary

Rotate it 90 degrees. Translate it so that it is in the 4th quadrant.
Reflect it over a line $y = \text{"a number"}$ so that the square is in the 1st quadrant.

Write 2 distinctly different ways that you can get the shape back in its original position.

Comment:

Students may want to use patty paper or a Mira to help with the transformations of their figure.

Answers will vary

2. On your graph paper draw and label a triangle. Describe its original position and size.

Answers will vary

Rotate, Translate, and Reflect the triangle so that the one side is touching an original side in such a way that it forms a parallelogram. List your steps here:

Answers will vary

3. On your graph paper draw and label a parallelogram. Describe its original position and size.

Answers will vary

Rotate, Translate, and Reflect the parallelogram several times, listing your steps here:

Answers will vary

Now, challenge a friend to get the parallelogram back into its original position! Are the steps that your friend used the reverse of your steps, or are they different?

Answers will vary

Introduction To Reflections, Translations, And Rotations

1. On your graph paper draw and label a square. Describe its original position and size.

Rotate it 90 degrees. Translate it so that it is in the 4th quadrant.

Reflect it over a line $y = \text{"a number"}$ so that the square is in the 1st quadrant.

Write 2 distinctly different ways that you can get the shape back in its original position.

2. On your graph paper draw and label a triangle. Describe its original position and size.

Rotate, Translate, and Reflect the triangle so that the one side is touching an original side in such a way that it forms a parallelogram. List your steps here:

Georgia Department of Education
Georgia Standards of Excellence Framework
GSE Grade 8 • Unit 1

3. On your graph paper draw and label a parallelogram. Describe its original position and size.

Rotate, Translate, and Reflect the parallelogram several times, listing your steps here:

Now, challenge a friend to get the parallelogram back into its original position! Are the steps that your friend used the reverse of your steps, or are they different?

Dilations In The Coordinate Plane

[Back to Task Table](#)

In this task, students will find rules to describe transformations.

STANDARDS FOR MATHEMATICAL CONTENT:

MGSE8.G.2 Understand that a two-dimensional figure is congruent to another if the second can be obtained from the first by a sequence of rotations, reflections, and translations; given two congruent figures, describe a sequence that exhibits the congruence between them.

MGSE8.G.3 Describe the effect of dilations, translations, rotations, and reflections on two-dimensional figures using coordinates.

MGSE8.G.4 Understand that a two-dimensional figure is similar to another if the second can be obtained from the first by a sequence of rotations, reflections, translations, and dilations; given two similar two-dimensional figures, describe a sequence that exhibits the similarity between them.

STANDARDS FOR MATHEMATICAL PRACTICE:

This task uses all of the practices with emphasis on:

1. Make sense of problems and persevere in solving them.
2. Reason abstractly and quantitatively.
3. Construct viable arguments and critique the reasoning of others.
4. Model with mathematics.
5. Use appropriate tools strategically.
6. Attend to precision.
7. Look for and make use of structure.

BACKGROUND KNOWLEDGE/TEACHER NOTES:

It may be helpful to review the new vocabulary: dilation - as well as reexamine vocabulary from the previous task: reflections, translations, and rotations. Find out what students know about the term dilation before beginning this task in order to get an idea of their understandings as the unit begins.

In order for students to be successful, students should be confident in their understandings of the following standards:

[MGSE5.G.1](#) [MGSE5.G.2](#) [MGSE6.G.3](#) [MGSE7.G.1](#)

COMMON MISCONCEPTIONS:

The following misconceptions are common among middle school students engaged in this unit:

- *Some students will continue to mix up the x and y axis.*
- *Students often will confuse “rules” for finding coordinates for dilations with the rules for rotations, translations, or reflections.*
- *Students often mis-label corresponding parts of congruent and/or similar figures on the coordinate plane.*
- *Students will need multiple opportunities to explore the transformation of figures in order to make sense of the patterns between the coordinates of the original and the transformed figure.*

In order to prevent or correct these misconceptions, any rules students use to determine coordinates for any transformation, should be determined by the students. This can be done through discovery in many of the tasks within this unit. When students make sense of these ideas, discover patterns for each of the three transformations, and discuss them with their peers, they will be less likely to develop these misconceptions and even correct some of them if they already exist. This saves the time of having to reteach much of these concepts again later.

ESSENTIAL QUESTIONS:

- What is a dilation and how does this transformation affect a figure in the coordinate plane?
- How can I tell if two figures are similar?
- In what ways can I represent the relationships that exist between similar figures using the scale factors, length ratios, and area ratios?
- What strategies can I use to determine missing side lengths and areas of similar figures?

MATERIALS

- graph paper
- colored pencils

GROUPING:

- *Individual/Partner/Small Group*

TASK DESCRIPTION, DEVELOPMENT AND DISCUSSION:

In this task, students will find rules to describe transformations in the coordinate plane. Rules of the form (nx, ny) transform a figure in the plane into a similar figure in the plane. This transformation is called a dilation with the center of dilation at the origin. The coefficient of x and y is the scale factor. Adding a number to x or y results in a translation of the original figure but does not affect the size. Thus, a more general rule for dilations centered at the origin is $(nx + a, ny + b)$. Teachers should support good student dialogue and take advantage of comments and questions to help guide students into correct mathematical thinking.

Students will also observe that congruence is a special case of similarity ($n = 1$). Congruent figures have the same size and shape. Transformations that preserve congruence are translations, reflections, and rotations.

DIFFERENTIATION:

Extension:

- Create an irregular polygon in the coordinate plane as the pre-image. Label the coordinates. Write the rule for a translation of your choosing. Graph the translated image. Write the new coordinates. Write the rule for a reflection of your choosing. Graph the reflected image. Write the new coordinates. Write the rule for a rotation of your choosing. Graph the rotated image. Write the new coordinates. Write the rule for a dilation of your choosing. Graph the dilated image. Write the new coordinates. Explain the transformations that your pre-image underwent.

Intervention/Scaffolding:

- Give students some time to work with the desmos graphing calculator. It's free and has so many applications for middle and high school students. The shape to dilate is a simple triangle, but as students move the sliders, they can see how changing those values transforms the shape as a dilation instantly.
<https://www.desmos.com/calculator/elccqxyf4w>
- You may need to graph Figure 1 with the class so that the students have an accurate idea of what the original figure looks like. Check each newly-graphed figure before having struggling students to move on to graph the next figure. Prompt struggling students by asking guiding questions.

Dilations In The Coordinate Plane

Adapted from *Stretching and Shrinking: Similarity*, *Connected Mathematics*, Dale Seymour Publications

Plot the ordered pairs given in the table to make six different figures. Draw each figure on a separate sheet of graph paper. Connect the points with line segments as follows:

- For Set 1, connect the points in order. Connect the last point in the set to the first point in the set.
- For Set 2, connect the points in order. Connect the last point in the set to the first point in the set.
- For Set 3, connect the points in order. Do not connect the last point in the set to the first point in the set.
- For Set 4, make a dot at each point (do not connect the dots).

Figure 1	Figure 2	Figure 3	Figure 4	Figure 5	Figure 6
Set 1	Set 1	Set 1	Set 1	Set 1	Set 1
(6, 4)	(12, 8)	(18, 4)	(18, 12)	(6, 12)	(8, 6)
(6, -4)	(12, -8)	(18, -4)	(18, -12)	(6, -12)	(8, -2)
(-6, -4)	(-12, -8)	(-18, -4)	(-18, -12)	(-6, -12)	(-4, -2)
(-6, 4)	(-12, 8)	(-18, 4)	(-18, 12)	(-6, 12)	(-4, 6)
Set 2	Set 2	Set 2	Set 2	Set 2	Set 2
(1, 1)	(2, 2)	(3, 1)	(3, 3)	(1, 3)	(3, 3)
(1, -1)	(2, -2)	(3, -1)	(3, -3)	(1, -3)	(3, 1)
(-1, -1)	(-2, -2)	(-3, -1)	(-3, -3)	(-1, -3)	(1, 1)
(-1, 1)	(-2, 2)	(-3, 1)	(-3, 3)	(-1, 3)	(1, 3)
Set 3	Set 3	Set 3	Set 3	Set 3	Set 3
(4, -2)	(8, -4)	(12, -2)	(12, -6)	(4, -6)	(6, 0)
(3, -3)	(6, -6)	(9, -3)	(9, -9)	(3, -9)	(5, -1)
(-3, -3)	(-6, -6)	(-9, -3)	(-9, -9)	(-3, -9)	(-1, -1)
(-4, -2)	(-8, -4)	(-12, -2)	(-12, -6)	(-4, -6)	(-2, 0)
Set 4	Set 4	Set 4	Set 4	Set 4	Set 4
(4, 2)	(8, 4)	(12, 2)	(12, 6)	(4, 6)	(6, 4)
(-4, 2)	(-8, 4)	(-12, 2)	(-12, 6)	(-4, 6)	(-2, 4)

Note: The scale used on the x- and y-axes in the figures below is 2 units. Each square is 4 square units (2 • 2).

Figure 1:

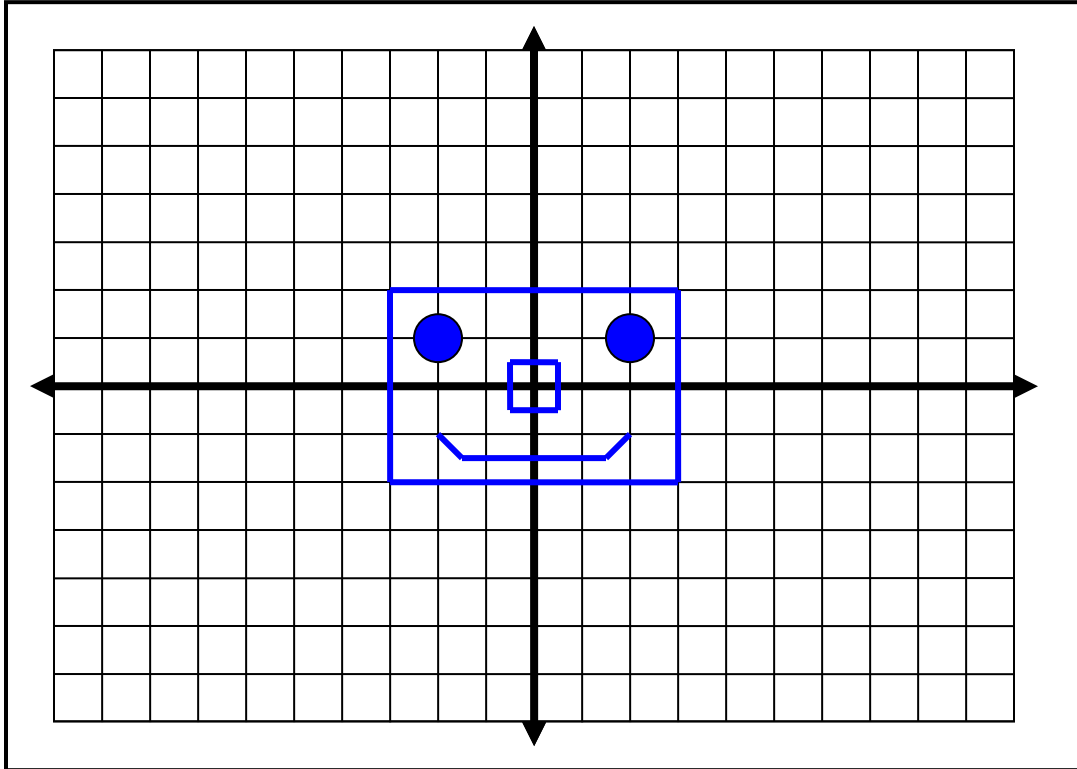

Figure 2:

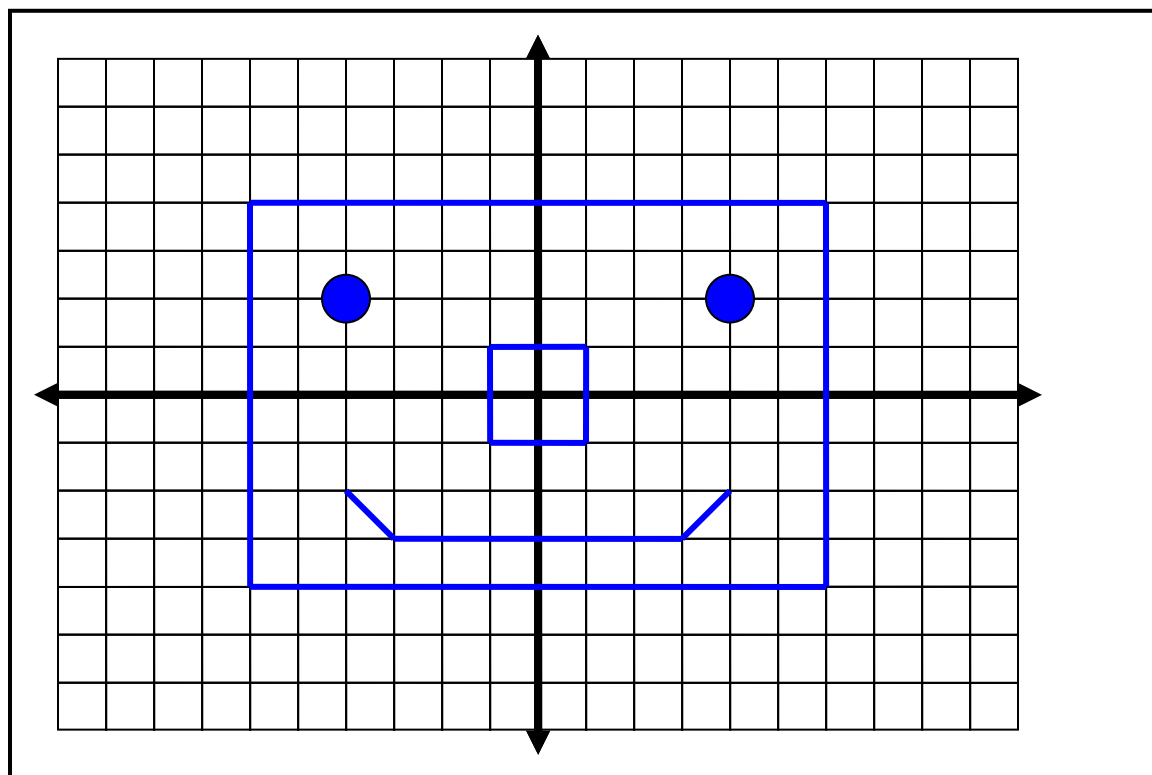

Figure 3:

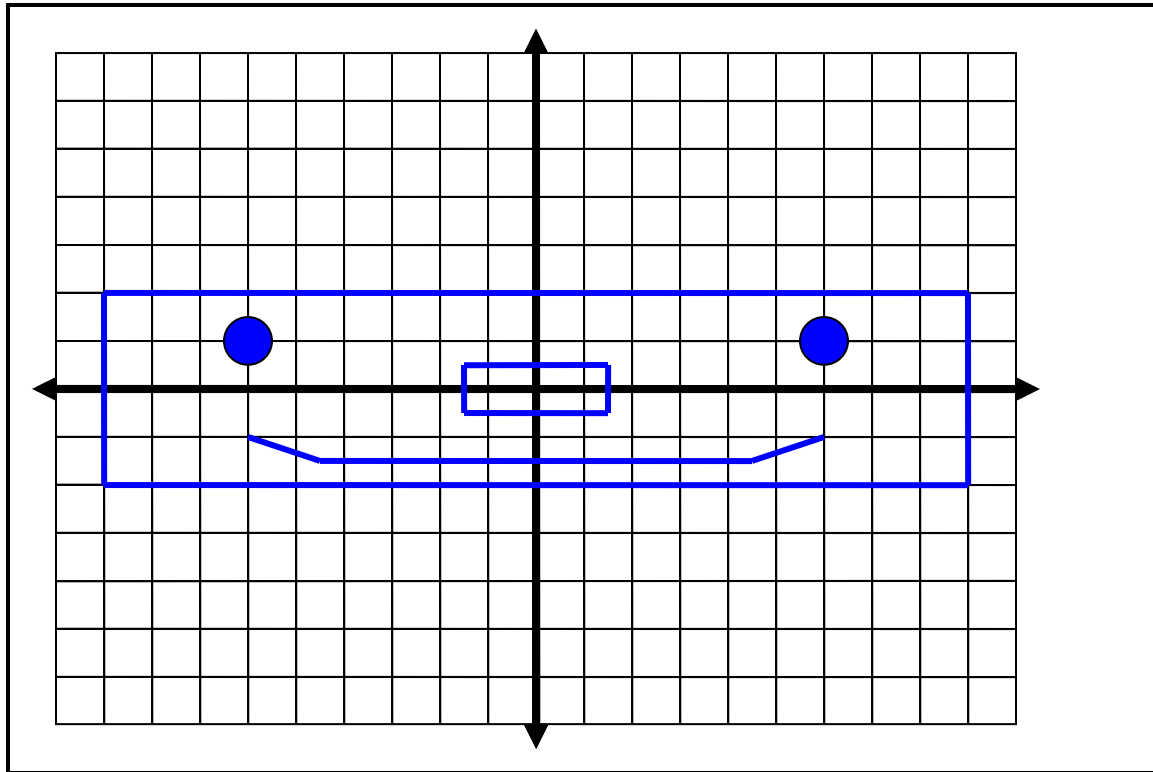

Figure 4:

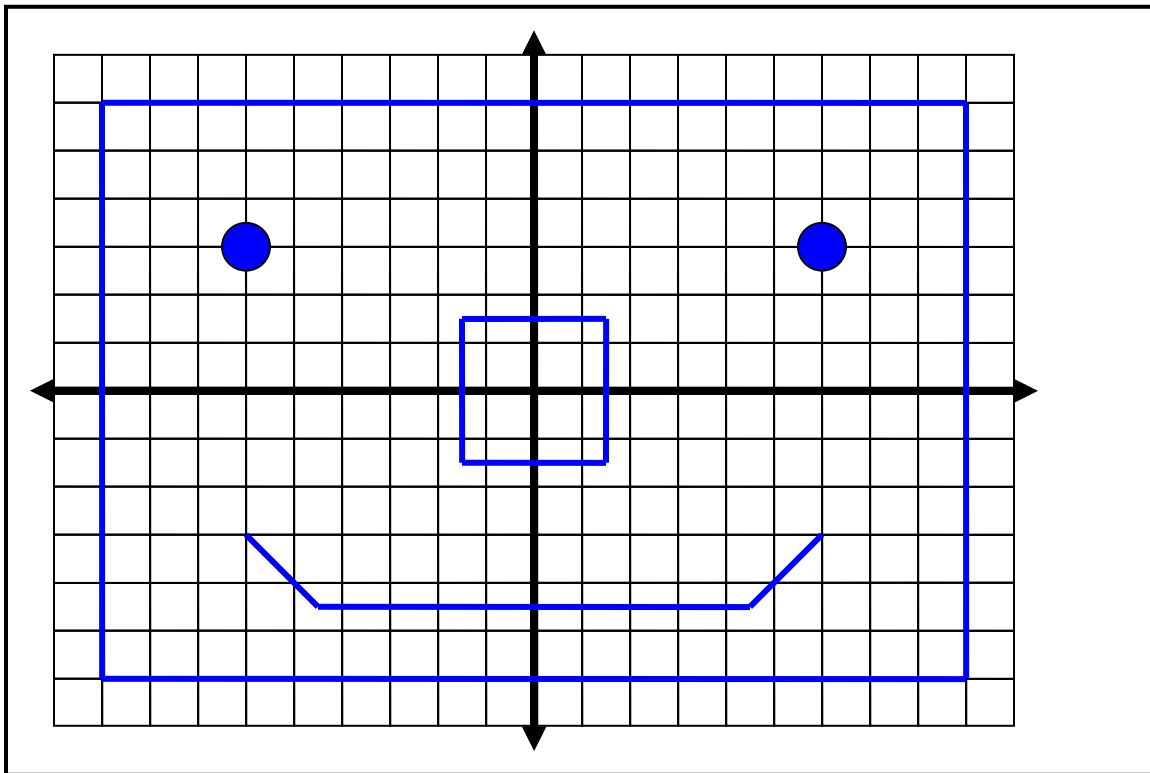

Figure 5:

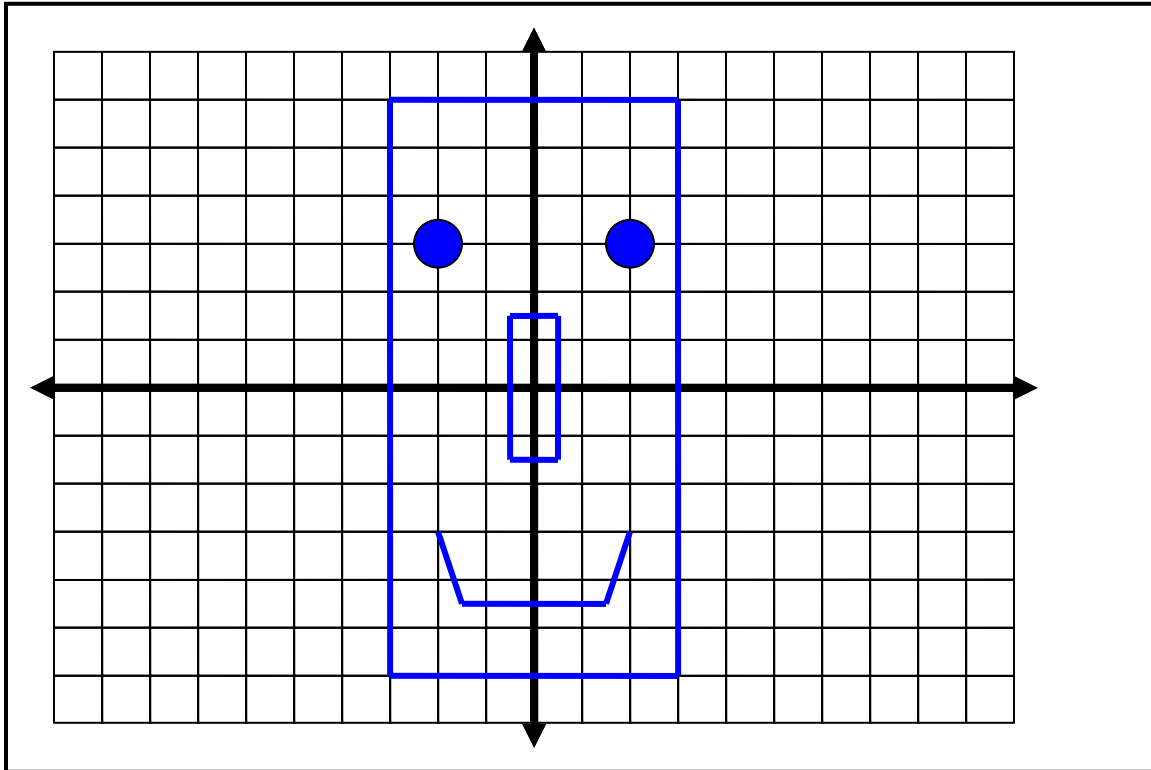
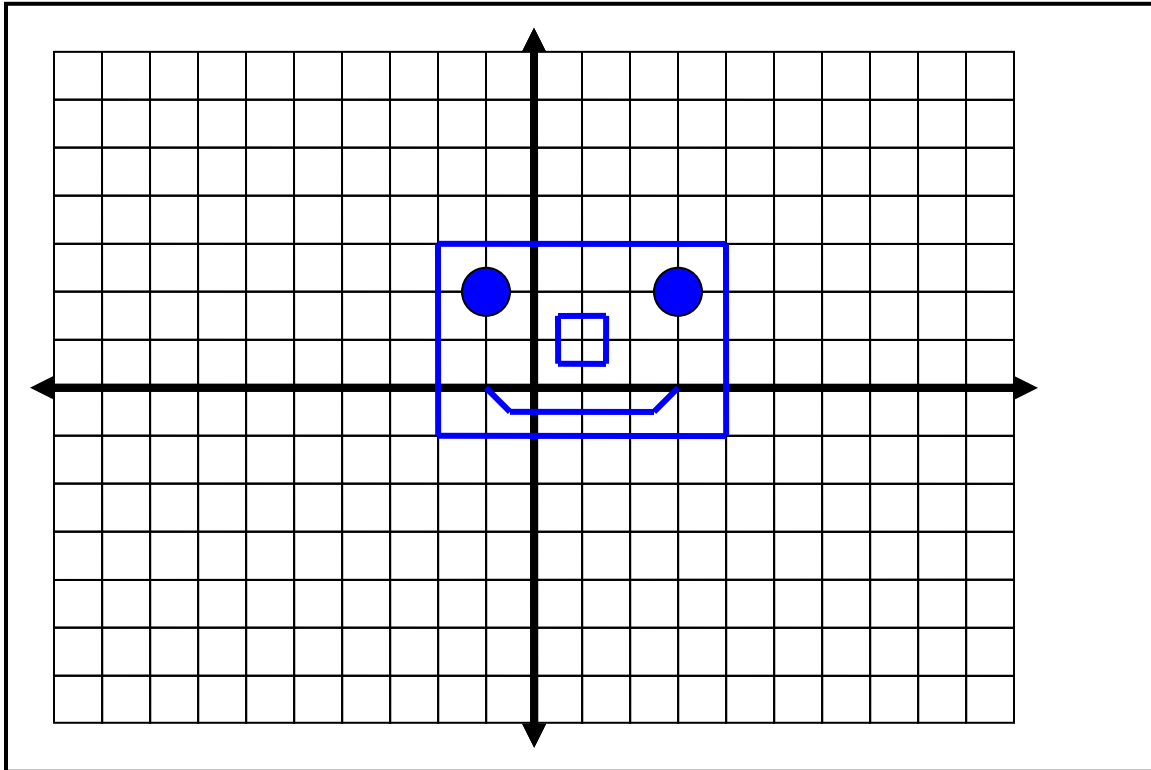

Figure 6:



After drawing the six figures, compare Figure 1 to each of the other figures and answer the following questions.

1. How do the coordinates of each figure compare to the coordinates of Figure 1? If possible, write general rules for making Figures 2-6.

Figure 2: Both the x and y coordinates are multiplied by 2. $(2x, 2y)$

Figure 3: The x coordinates in Figure 3 are three times the corresponding x coordinates in Figure 1; the y coordinates are the same. $(3x, y)$

Figure 4: Both the x and y coordinates are multiplied by 3. $(3x, 3y)$

Figure 5: The x coordinates in Figure 5 are the same as the corresponding x coordinates in Figure 1. The y coordinates are three times the corresponding y coordinates in Figure 1. $(x, 3y)$

Figure 6: Two is added to both the x and y coordinates. $(x + 2, y + 2)$

2. Describe any similarities and/or differences between Figure 1 and each of the other figures.
 - Describe how corresponding sides compare.
 - Describe how corresponding angles compare.

Figure 2 is an enlargement of Figure 1. The figures have the same shape but different sizes. The ratio of the lengths of the corresponding sides is 1 to 2. The corresponding angles are equal in measure.

Figure 3 is wider or longer than Figure 1. The figures are different shapes and sizes. The ratio of the lengths of the corresponding sides is not constant. For one dimension, the ratio is 1 to 3; for the other dimension, the ratio is 1 to 1. The corresponding angles are equal in measure.

Figure 4 is an enlargement of Figure 1. The figures have the same shape but different sizes. The ratio of the lengths of the corresponding sides is 1 to 3. The corresponding angles are equal in measure.

Figure 5 is taller than Figure 1. The figures have different shapes and sizes. The ratio of the lengths of the corresponding sides is not constant. For one dimension, the ratio is 1 to 3; for the other dimension, the ratio is 1 to 1. The corresponding angles are equal in measure.

Figure 6 is the same shape and size as Figure 1. Figure 1 is shifted (i.e., translated) up and to the right to get Figure 6. The ratio of the lengths of the corresponding sides is 1 to 1. The corresponding angles are equal in measure.

3. What would be the effect of multiplying each of the coordinates in Figure 1 by $\frac{1}{2}$?

The figure would shrink and the lengths of the sides would be half as long. [Note to teachers: Students may say that the new figure is “ $\frac{1}{2}$ the size” of the original figure which might imply that the area of the new figure is $\frac{1}{2}$ the area of the original. In actuality, the area of the new figure is $\frac{1}{2} \cdot \frac{1}{2}$ or $\frac{1}{4}$ the size of the original figure. Be sure that students understand that the side lengths are reduced by a factor of $\frac{1}{2}$.]

4. Which figures are similar? Describe a sequence of transformations that takes Figure 1 to the similar figure.

Figures 1, 2, 4 and 6 are similar. Students may observe visually that these figures have the same shape but are different sizes (except for Figure 6). Figure 6 is congruent to Figure 1. Note that congruence is a special case of similarity – figures have the same size and shape. Figures 3 and 5 are longer (or taller) and skinnier. Students may also notice that corresponding angles are equal for all figures. The scale factor from Figure 1 to Figure 2 is 2. The transformation is a dilation of 2. The scale factor from Figure 1 to Figure 4 is 3. The transformation is a dilation of 3. The scale factor from Figure 1 to Figure 6 is 1 because it is congruent to Figure 1. The transformation is a translation up two and right two.

5. Translate, reflect, rotate (between 0 and 90°), and dilate Figure 1 so that it lies entirely in Quadrant III on the coordinate plane. You may perform the transformations in any order that you choose. Draw a picture of the new figure at each step and explain the procedures you followed to get the new figure. Use coordinates to describe the transformations and give the scale factor you used. Describe the similarities and differences between your new figures and Figure 1.

Answers will vary depending on the transformations that students use. The translation, reflection, and rotation do not change the size or shape of the figure. The final figure is a reduction or enlargement of Figure 1 and it has a different orientation in the coordinate plane because of the reflection and rotation.

Dilations In The Coordinate Plane

Adapted from *Stretching and Shrinking: Similarity*, *Connected Mathematics*, Dale Seymour Publications

Plot the ordered pairs given in the table to make six different figures. Draw each figure on a separate sheet of graph paper. Connect the points with line segments as follows:

- For Set 1, connect the points in order. Connect the last point in the set to the first point in the set.
- For Set 2, connect the points in order. Connect the last point in the set to the first point in the set.
- For Set 3, connect the points in order. Do not connect the last point in the set to the first point in the set.
- For Set 4, make a dot at each point (do not connect the dots).

After drawing the six figures, compare Figure 1 to each of the other figures and answer the following questions.

1. How do the coordinates of each figure compare to the coordinates of Figure 1? If possible, write general rules for making Figures 2-6.
2. Describe any similarities and/or differences between Figure 1 and each of the other figures.
 - Describe how corresponding sides compare.
 - Describe how corresponding angles compare.
3. What would be the effect of multiplying each of the coordinates in Figure 1 by $\frac{1}{2}$?
4. Which figures are similar? Describe a sequence of transformations that takes Figure 1 to the similar figure.
5. Translate, reflect, rotate (between 0 and 90°), and dilate Figure 1 so that it lies entirely in Quadrant III on the coordinate plane. You may perform the transformations in any order that you choose. Draw a picture of the new figure at each step and explain the procedures you followed to get the new figure. Use coordinates to describe the transformations and give the scale factor you used. Describe the similarities and differences between your new figures and Figure 1.

Georgia Department of Education
 Georgia Standards of Excellence Framework
GSE Grade 8 • Unit 1

Figure 1	Figure 2	Figure 3	Figure 4	Figure 5	Figure 6
Set 1	Set 1	Set 1	Set 1	Set 1	Set 1
(6, 4)	(12, 8)	(18, 4)	(18, 12)	(6, 12)	(8, 6)
(6, -4)	(12, -8)	(18, -4)	(18, -12)	(6, -12)	(8, -2)
(-6, -4)	(-12, -8)	(-18, -4)	(-18, -12)	(-6, -12)	(-4, -2)
(-6, 4)	(-12, 8)	(-18, 4)	(-18, 12)	(-6, 12)	(-4, 6)
Set 2	Set 2	Set 2	Set 2	Set 2	Set 2
(1, 1)	(2, 2)	(3, 1)	(3, 3)	(1, 3)	(3, 3)
(1, -1)	(2, -2)	(3, -1)	(3, -3)	(1, -3)	(3, 1)
(-1, -1)	(-2, -2)	(-3, -1)	(-3, -3)	(-1, -3)	(1, 1)
(-1, 1)	(-2, 2)	(-3, 1)	(-3, 3)	(-1, 3)	(1, 3)
Set 3	Set 3	Set 3	Set 3	Set 3	Set 3
(4, -2)	(8, -4)	(12, -2)	(12, -6)	(4, -6)	(6, 0)
(3, -3)	(6, -6)	(9, -3)	(9, -9)	(3, -9)	(5, -1)
(-3, -3)	(-6, -6)	(-9, -3)	(-9, -9)	(-3, -9)	(-1, -1)
(-4, -2)	(-8, -4)	(-12, -2)	(-12, -6)	(-4, -6)	(-2, 0)
Set 4	Set 4	Set 4	Set 4	Set 4	Set 4
(4, 2)	(8, 4)	(12, 2)	(12, 6)	(4, 6)	(6, 4)
(-4, 2)	(-8, 4)	(-12, 2)	(-12, 6)	(-4, 6)	(-2, 4)

Changing Shapes

[Back to Task Table](#)

In this task, students will identify effects of transforming by a rule.

STANDARDS FOR MATHEMATICAL CONTENT:

MGSE8.G.3 Describe the effect of dilations, translations, rotations, and reflections on two-dimensional figures using coordinates.

MGSE8.G.4 Understand that a two-dimensional figure is similar to another if the second can be obtained from the first by a sequence of rotations, reflections, translations, and dilations; given two similar two-dimensional figures, describe a sequence that exhibits the similarity between them.

STANDARDS FOR MATHEMATICAL PRACTICE:

This task uses all of the practices with emphasis on:

1. Make sense of problems and persevere in solving them.
2. Reason abstractly and quantitatively.
3. Construct viable arguments and critique the reasoning of others.
4. Model with mathematics.
5. Use appropriate tools strategically.
6. Attend to precision.
7. Look for and make use of structure.

BACKGROUND KNOWLEDGE/TEACHER NOTES:

It may be helpful to open this task with a discussion regarding the new vocabulary: reflections, translations, dilations, and rotations. Check students' understandings of these terms throughout this unit in order to avoid misconceptions that could creep up from task to task. It's better to catch these misconceptions early on rather than later.

In order for students to be successful, students should be confident in their understandings of the following standards:

[MGSE5.G.1](#) [MGSE5.G.2](#) [MGSE6.G.3](#) [MGSE7.G.1](#)

COMMON MISCONCEPTIONS:

The following misconceptions are common among middle school students engaged in this unit:

- *Students often mix up the x and y axis.*
- *Students often will confuse "rules" for finding coordinates for dilations with the rules for rotations, translations, or reflections.*
- *Students often mis-label corresponding parts of congruent and/or similar figures on the coordinate plane.*

- *Students will need multiple opportunities to explore the transformation of figures in order to make sense of the patterns between the coordinates of the original and the transformed figure.*

In order to prevent or correct these misconceptions, any rules students use to determine coordinates for any transformation, should be determined by the students. This can be done through discovery in many of the tasks within this unit. When students make sense of these ideas, discover patterns for each of the three transformations, and discuss them with their peers, they will be less likely to develop these misconceptions and even correct some of them if they already exist. This saves the time of having to reteach much of these concepts again later.

ESSENTIAL QUESTIONS:

- What is a dilation and how does this transformation affect a figure in the coordinate plane?
- How can I tell if two figures are similar?

MATERIALS:

- Changing Shapes Handout
- graph paper
- colored pencils

GROUPING:

- *Individual/Partner*

TASK DESCRIPTION, DEVELOPMENT AND DISCUSSION:

In this task, students' ability to identify the effects of transforming a figure according to a rule involving dilations and/or translations will be assessed. Teachers should support good student dialogue and take advantage of comments and questions to help guide students into correct mathematical thinking.

DIFFERENTIATION:

Extension:

- Students in need of an extension to this activity can create an original figure, perform at least 3 transformations and graph the transformed figure on a new sheet of graph paper. Students can share both figures and the task is to see if you can find the transformations the student used to create the new figure. Does the order of the transformations used, matter? Can the new figure be created using fewer transformations than the creator used? A variation: Give the original (or the transformed figure) and the transformations used. Can you find the transformed figure (or the original figure)?

Intervention:

- Revisit individual transformations and allow students requiring an intervention to have some more practice with these transformations prior to assigning this task.

Changing Shapes

Suppose you are going to be designing a logo for a club at your school. To prepare for this project, draw a non-rectangular shape in the coordinate plane so that portions of the shape are in each of the four quadrants. Explain what would happen to your shape if you transformed it using each of the given rules with the center of dilation at the origin.

a. $(4x, 4y)$

Solution

The figure would grow by a scale factor of 4. The distance from the origin to the object would increase by a scale factor of 4.

b. $(0.25x, 0.25y)$

Solution

The figure would shrink by a scale factor of 0.25. The distance from the origin to the object would decrease by a scale factor of 0.25.

c. $(2x, y)$

Solution

The figure would increase on one dimension by a scale factor of 2; the other dimension would stay the same.

d. $(3x, 3y + 5)$

Solution

The figure would grow by a scale factor of 3 and move up 5 units.

e. $(x + 5, y - 5)$

Solution

The figure would move right five units and down five units.

f. $(\frac{1}{2}x - 1, \frac{1}{2}y)$

Solution

The figure would shrink by a scale factor of $\frac{1}{2}$ and move left 1 unit.

g. Will any of the transformed figures be similar to the original figure? Explain.

Solution

Figures a, b, d, e, and f will be similar to the original figure. Both dimensions increase by the same scale factor. Figure e will be congruent to the original figure because the side lengths and shape do not change. The ratio of the lengths of the corresponding sides will be 1:1 and the measures of the corresponding angles will be equal. Note that congruence is a special case of similarity. [Figure e is congruent to the original figure.]

- h. If you make a new figure by adding 2 units to the length of each side of your shape, will the two figures be similar? Why or why not?

Solution

The figures would not be similar. Adding a constant amount to each side will distort the figure. The ratio of the lengths of the corresponding sides will not be constant.

- i. Write a general rule for transformations in the plane that produce similar figures.

Solution

$(nx + a, ny + b)$

Changing Shapes

Suppose you are going to be designing a logo for a club at your school. To prepare for this project, draw a non-rectangular shape in the coordinate plane so that portions of the shape are in each of the four quadrants. Explain what would happen to your shape if you transformed it using each of the given rules with the center of dilation at the origin.

- a. $(4x, 4y)$
- b. $(0.25x, 0.25y)$
- c. $(2x, y)$
- d. $(3x, 3y + 5)$
- e. $(x + 5, y - 5)$
- f. $(\frac{1}{2}x - 1, \frac{1}{2}y)$
- g. Will any of the transformed figures be similar to the original figure? Explain.
- h. If you make a new figure by adding 2 units to the length of each side of your shape, will the two figures be similar? Why or why not?
- i. Write a general rule for transformations in the plane that produce similar figures.

Coordinating Reflections

[Back to Task Table](#)

In this task, students will develop a formal definition for reflection, translation, and rotation.

STANDARDS FOR MATHEMATICAL CONTENT:

MGSE8.G.3 Describe the effect of dilations, translations, rotations, and reflections on two-dimensional figures using coordinates.

STANDARDS FOR MATHEMATICAL PRACTICE:

This task uses all of the practices with emphasis on:

1. Make sense of problems and persevere in solving them.
3. Construct viable arguments and critique the reasoning of others.
4. Model with mathematics.
5. Use appropriate tools strategically.
6. Attend to precision.
7. Look for and make use of structure.

BACKGROUND KNOWLEDGE/TEACHER NOTES:

It may be helpful to check student understanding of the new vocabulary: reflections, translations, dilations, and rotations.

In order for students to be successful, students should be confident in their understandings of the following standards:

[MGSE5.G.1](#) [MGSE5.G.2](#) [MGSE6.G.3](#) [MGSE7.G.1](#)

COMMON MISCONCEPTIONS:

The following misconceptions are common among middle school students engaged in this unit:

- *Students often mix up the x and y axis.*
- *Students often will confuse “rules” for finding coordinates for dilations with the rules for rotations, translations, or reflections.*
- *Students often mis-label corresponding parts of congruent and/or similar figures on the coordinate plane.*
- *Students will need multiple opportunities to explore the transformation of figures in order to make sense of the patterns between the coordinates of the original and the transformed figure.*

In order to prevent or correct these misconceptions, any rules students use to determine coordinates for any transformation, should be determined by the students. This can be done through discovery in many of the tasks within this unit. When students make sense of these ideas,

discover patterns for each of the three transformations, and discuss them with their peers, they will be less likely to develop these misconceptions and even correct some of them if they already exist. This saves the time of having to reteach much of these concepts again later.

ESSENTIAL QUESTION:

- How can the coordinate plane help me understand properties of reflections, translations and rotations?

MATERIALS:

- Mira™ or reflective mirror or Patty Paper

GROUPING:

- *Individual/Partner*

TASK DESCRIPTION, DEVELOPMENT AND DISCUSSION:

This task is designed to develop a formal definition for reflection. Students should develop the understanding that a reflection is not merely an image, but an action that maps an object to another location on the plane. This should build upon activities from previous grades that introduced and discussed symmetry, and teachers may find it helpful to use additional activities utilizing a MIRA™ or patty paper.

It is highly recommended that teachers use tools such as a Mira™, mirrors and patty paper or tracing paper to assist developing conceptual understandings of the geometry and to reinforce what was used in earlier units on symmetry.

DIFFERENTIATION:

Extension:

- This is an investigation/practice activity that students can complete on the computer. The game, Flip-n-Slide involves reflections, translations, and various lines of reflection. Students may play with a partner or against the computer.
<http://calculationnation.nctm.org/Games/>

Intervention/Scaffolding:

Have students graph as instructed, then discuss problems 1 & 2 with struggling students before having them do the rest of the task. Prompt struggling students by asking the least helpful question possible in order for students to think for themselves and build their own understanding of reflections and the affect they have on coordinates.

Coordinating Reflections

Antonio and his friend Brittany were at a summer math camp that had a large *coordinate plane* drawn on the gym floor. Antonio challenged Brittany to try and mirror him as he traveled around the first quadrant.

Map Antonio's and Brittany's movements on this coordinate plane:

Antonio began at $(2, 1)$ and walked to $(3, 5)$; Brittany decided to begin at $(-2, 1)$, then tried to mirror Antonio by walking to $(-3, 5)$. Antonio jumped to $(5, 5)$ and side-stepped to $(4, 3)$; Brittany jumped to $(-5, 5)$ then side-stepped to $(-4, 3)$. Antonio returned to $(2, 1)$ and Brittany returned to $(-2, 1)$.

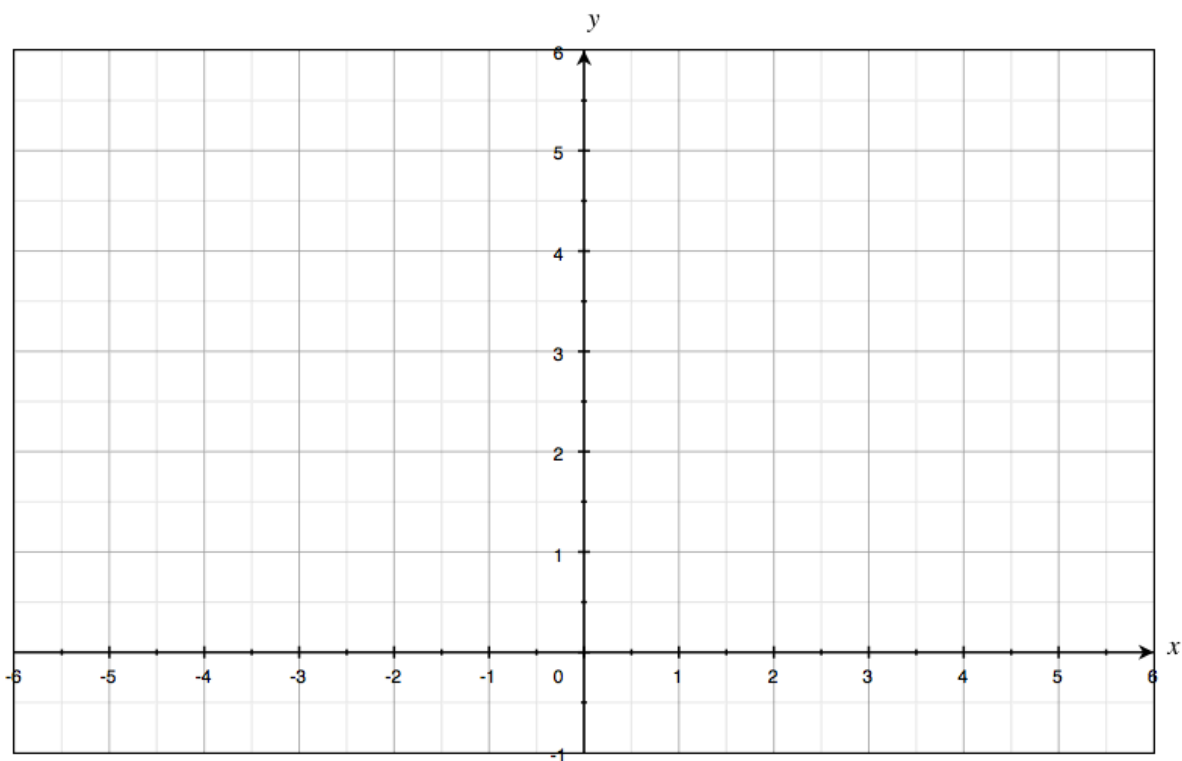

1. Did Brittany mirror Antonio?
 - If you answered no, identify the incorrect coordinates Brittany used and find the correct coordinates. Explain your decision and identify the line of symmetry she should have used as a mirror. How did you know that this should have been the line of symmetry?

- If you answered yes, identify the line of symmetry Brittany used as a mirror. How did you know it was the line of symmetry?

Yes, Brittany mirrored Antonio. The line of symmetry (line of reflection) is the y-axis. Students should recognize through a class discussion that the y-axis is a “mirror” or reflection line. Some may argue that Brittany should have moved initially to $(-1, 5)$, which is moving the same distance and direction as Antonio and results in a translation. Teachers should guide the discussion with questions such as:

- *What does it mean to mirror? What exactly is being mirrored?*
- *What happens to your image in a mirror if you walk toward it? Or away from it?*
- *Do mirrored objects always have a reflection line?*
- *How could you determine where the reflection line is?*

2. If Brittany had instead begun at $(-2, 1)$, walked to $(-4, 3)$, side-stepped to $(-5, 5)$, jumped to $(-3, 5)$ and then returned to $(-2, 1)$, could she claim that she created a mirror image of Antonio’s path? Justify your answer.

Yes, the completed path is a mirror image. Students should provide a justification for their answer that can help them develop the definition of reflections. During whole group discussions, teachers should use student justifications and debates about the questions to help students come to a consensus about a definition that is not dependent upon the particular movement of Brittany. Instead it is dependent upon creating a set of corresponding points that are reflected across the line of reflection.

Antonio and Brittany decided to change the game and use some lettered blocks to mark points they visited on the grid. Antonio placed blocks *A*, *B*, and *C* as indicated by the points below, then drew a chalk line between them.

Comments:

Students should recall that they can fold the page along the x-axis to check their work. Students should discuss strategies for determining if points are reflected, including folding papers along the line of reflection and verifying the distance of corresponding points from the reflection line. It is critical to discuss that corresponding points with non-integer coordinates are still equidistant from the reflection line.

3. Draw this figure on a separate sheet of graph paper. Label the coordinates Antonio used, and then construct the graph of where Brittany would place her blocks if she correctly reflected Antonio's figure across the x -axis.

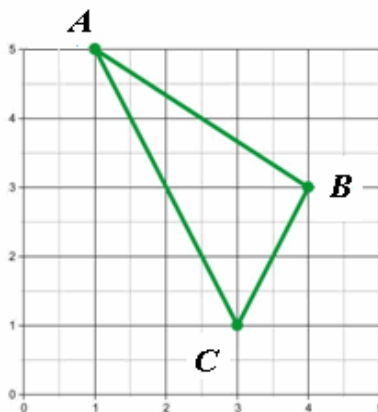

The point (1, 5) would be mapped to (1, -5), the point (4, 3) would be mapped to (4, -3), and the point (3, 1) would be mapped to the point (3, -1).

4. Describe how you determined where to place Brittany's blocks.

Flipping the blocks (points) over the x -axis means that the y coordinate now is the negative of the point flipped or reflected.

5. Each block Brittany placed corresponds to one that Antonio placed. List each pair of coordinates that correspond.

A (1, 5) and A' (1, -5); B (3, 1), B' (3, -1) and (4, 3), (4, -3)

6. What can you observe about the distances between each of Antonio's blocks and the corresponding block Brittany placed?

The distance is twice the y coordinate of the block/point being reflected.

7. If Antonio walked 2 feet from his block A toward his block C, and Brittany mirrored his movement by walking 2 feet from the blocks corresponding to A and C, would Brittany and Antonio be the same distance from the reflection line? How can you be certain?

The distances will be the same. It is critical to discuss that corresponding points with non-integer coordinates are still equidistant from the reflection line.

8. How would you define a reflection now that you have analyzed some of the properties of reflected images using the coordinate plane?

A reflection flips a point over the line of reflection so that the result looks like a mirrored image, with the line of reflection being the mirror.

Coordinating Reflections

Antonio and his friend Brittany were at a summer math camp that had a large *coordinate plane* drawn on the gym floor. Antonio challenged Brittany to try and mirror him as he traveled around the first quadrant.

Map Antonio's and Brittany's movements on this coordinate plane:

Antonio began at $(2, 1)$ and walked to $(3, 5)$; Brittany decided to begin at $(-2, 1)$, then tried to mirror Antonio by walking to $(-3, 5)$. Antonio jumped to $(5, 5)$ and side-stepped to $(4, 3)$; Brittany jumped to $(-5, 5)$ then side-stepped to $(-4, 3)$. Antonio returned to $(2, 1)$ and Brittany returned to $(-2, 1)$.

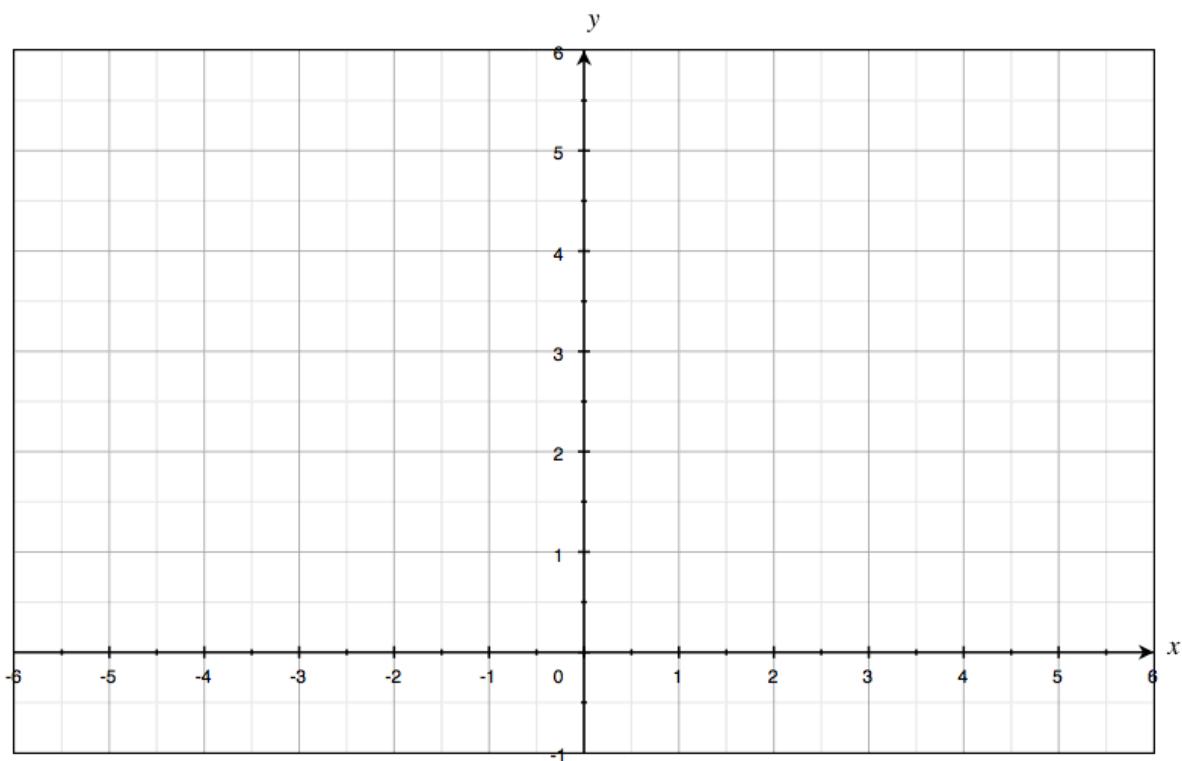

1. Did Brittany mirror Antonio?
 - If you answered no, identify the incorrect coordinates Brittany used and find the correct coordinates. Explain your decision and identify the line of symmetry she should have used as a mirror. How did you know that this should have been the line of symmetry?
 - If you answered yes, identify the line of symmetry Brittany used as a mirror. How did you know it was the line of symmetry?
2. If Brittany had instead begun at $(-2,1)$, walked to $(-4,3)$, side-stepped to $(-5,5)$, jumped to $(-3,5)$ and then returned to $(-2,1)$, could she claim that she created a mirror image of Antonio's path? Justify your answer.

Antonio and Brittany decided to change the game and use some lettered blocks to mark points they visited on the grid. Antonio placed blocks *A*, *B*, and *C* as indicated by the points below, then drew a chalk line between them.

3. Draw this figure on a separate sheet of graph paper. Label the coordinates Antonio used, and then construct the graph of where Brittany would place her blocks if she correctly reflected Antonio's figure across the x -axis.

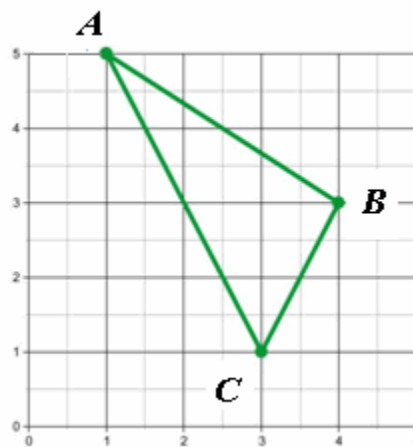

4. Describe how you determined where to place Brittany's blocks.
5. Each block Brittany placed corresponds to one that Antonio placed. List each pair of coordinates that correspond.

Georgia Department of Education
Georgia Standards of Excellence Framework
GSE Grade 8 • Unit 1

6. What can you observe about the distances between each of Antonio's blocks and the corresponding block Brittany placed?

7. If Antonio walked 2 feet from his block *A* toward his block *C*, and Brittany mirrored his movement by walking 2 feet from the blocks corresponding to *A* and *C*, would Brittany and Antonio be the same distance from the reflection line? How can you be certain?

8. How would you define a reflection now that you have analyzed some of the properties of reflected images using the coordinate plane?

Coordinating Translations

[Back to Task Table](#)

In this task, students will develop a formal definition for reflection, translation, and rotation.

STANDARDS FOR MATHEMATICAL CONTENT:

MGSE8.G.3 Describe the effect of dilations, translations, rotations, and reflections on two-dimensional figures using coordinates.

STANDARDS FOR MATHEMATICAL PRACTICE:

This task uses all of the practices with emphasis on:

1. Make sense of problems and persevere in solving them.
3. Construct viable arguments and critique the reasoning of others.
4. Model with mathematics.
5. Use appropriate tools strategically.
6. Attend to precision.
7. Look for and make use of structure.

BACKGROUND KNOWLEDGE/TEACHER NOTES:

It may be helpful to check students' understanding of the new vocabulary: reflections, translations, dilations and rotations as well as find out what they "know" about the effects these transformations have on points in the plane.

In order for students to be successful, students should be confident in their understandings of the following standards:

[MGSE5.G.1](#) [MGSE5.G.2](#) [MGSE6.G.3](#) [MGSE7.G.1](#)

COMMON MISCONCEPTIONS:

The following misconceptions are common among middle school students engaged in this unit:

- *Students often confuse the x and y axis.*
- *Students often will confuse "rules" for finding coordinates for translations with the rules for rotations, dilations, and reflections.*
- *Students often mis-label corresponding parts of congruent and/or similar figures on the coordinate plane.*
- *Students will need multiple opportunities to explore the transformation of figures in order to make sense of the patterns between the coordinates of the original and the transformed figure.*

In order to prevent or correct these misconceptions, any rules students use to determine coordinates for any transformation, should be determined by the students. This can be done through discovery in many of the tasks within this unit. When students make sense of these ideas, discover patterns for each of the three transformations, and discuss them with their peers, they will be less likely to develop these misconceptions and even correct some of them if they already exist. This saves the time of having to reteach much of these concepts again later.

ESSENTIAL QUESTION:

- How can the coordinate plane help me understand properties of reflections, translations and rotations?

MATERIALS:

- Mira™ or reflective mirror
- graph paper
- patty paper or tracing paper (optional)

GROUPING:

- *Individual/Partner*

TASK DESCRIPTION, DEVELOPMENT AND DISCUSSION:

This task is designed to develop a formal definition for translation. Students should develop the understanding that a reflection is not merely an image, but an action that maps an object to another location on the plane. This should build upon activities from previous grades that introduced and discussed symmetry, and teachers may find it helpful to use additional activities utilizing a MIRA™ or patty paper.

It is highly recommended that teachers use tools such as a Mira™, mirrors and patty paper or tracing paper to assist developing conceptual understandings of the geometry and to reinforce what was used in earlier units on symmetry.

Background Information

- Translations and rotations are repeated reflections.

DIFFERENTIATION:

Extension:

- This is an investigation/practice activity that students can complete on the computer. The game, Flip-n-Slide involves reflections, translations, and various lines of reflection. Students may play with a partner or against the computer.
<http://calculationnation.nctm.org/Games/>
- This is an investigation activity students can complete on the computer involving translations. Practice problems are included.
[.http://www.mathsisfun.com/geometry/translation.html](http://www.mathsisfun.com/geometry/translation.html)

Intervention:

- Have students graph as instructed, then discuss problems 1 & 2 with struggling students before having them do the rest of the task. Prompt struggling students by asking the least helpful question possible in order for students to think for themselves and build their own understanding of reflections and the affect they have on coordinates.

Coordinating Translations

Your task is to plot any creative polygon you want on the coordinate plane, and then create polygons congruent to the one you designed using the three translations described below.

1. Translate the original polygon right 5 units. For each vertex of your original polygon in the form (x, y) , what is its image's coordinates? What is the general form for the image's vertices?

$$(x + 5, y)$$

2. Translate the original polygon down 4 units. For each vertex of your original polygon in the form (x, y) , what is its image's coordinates? What is the general form for the image's vertices?

$$(x, y - 4)$$

3. Translate the original polygon left 4 units and up 2 units. For each vertex of your original polygon in the form (x, y) , what is its image's coordinates? What is the general form for the image's vertices?

$$(x - 4, y + 2)$$

The vertices of your original polygon combined with their images must be mapped to points in all four quadrants of the coordinate plane to receive full credit.

Answers will vary. Teachers should encourage students to make fairly simple polygons at first, but then move to more complicated designs. Students should also recognize through class discussion that all points, not merely integer coordinates would be translated using the notation $(x + h, y + k)$. As an extension, teachers can use a variety of rational number coordinates.

Differentiation

Provide a description of each of the following translations, where h and k can represent any number.

1. $(x + h, y + k)$

H moves each point right or left $|h|$ units depending upon the sign of h . k moves each point up or down $|k|$ units depending upon its sign.

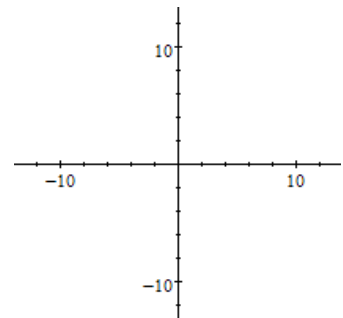

Coordinating Translations

Your task is to plot any creative polygon you want on the coordinate plane, and then create polygons congruent to the one you designed using the three translations described below.

1. Translate the original polygon right 5 units. For each vertex of your original polygon in the form (x, y) , what is its image's coordinates? What is the general form for the image's vertices?
2. Translate the original polygon down 4 units. For each vertex of your original polygon in the form (x, y) , what is its image's coordinates? What is the general form for the image's vertices?
3. Translate the original polygon left 4 units and up 2 units. For each vertex of your original polygon in the form (x, y) , what is its image's coordinates? What is the general form for the image's vertices?

The vertices of your original polygon combined with their images must be mapped to points in all four quadrants of the coordinate plane to receive full credit.

Differentiation

Provide a description of each of the following translations, where h and k can represent any number.

1. $(x + h, y + k)$

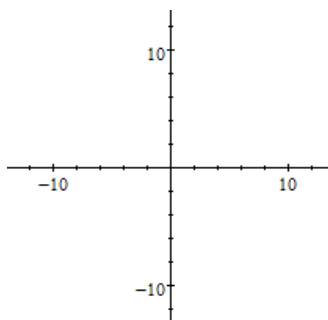

Coordinating Rotations

[Back to Task Table](#)

In this task, students will develop a formal definition for reflection, translation, and rotation.

STANDARDS FOR MATHEMATICAL CONTENT:

MGSE8.G.3 Describe the effect of dilations, translations, rotations, and reflections on two-dimensional figures using coordinates.

STANDARDS FOR MATHEMATICAL PRACTICE:

This task uses all of the practices with emphasis on:

1. Make sense of problems and persevere in solving them.
3. Construct viable arguments and critique the reasoning of others.
4. Model with mathematics.
5. Use appropriate tools strategically.
6. Attend to precision.
7. Look for and make use of structure.

BACKGROUND KNOWLEDGE/TEACHER NOTES:

It may be helpful to check students' understanding of the new vocabulary: reflections, translations, dilations and rotations as well as find out what they "know" about the effects these transformations have on points in the plane.

In order for students to be successful, students should be confident in their understandings of the following standards:

[MGSE5.G.1](#) [MGSE5.G.2](#) [MGSE6.G.3](#) [MGSE7.G.1](#)

COMMON MISCONCEPTIONS:

The following misconceptions are common among middle school students engaged in this unit:

- *Some students will mix up clockwise and counterclockwise directions.*
- *Students often mix up the x and y axis.*
- *Students often will confuse "rules" for finding coordinates for translations with the rules for rotations, dilations, and reflections.*
- *Students often mis-label corresponding parts of congruent and/or similar figures on the coordinate plane.*

- *Students will need multiple opportunities to explore the transformation of figures in order to make sense of the patterns between the coordinates of the original and the transformed figure.*

In order to prevent or correct these misconceptions, any rules students use to determine coordinates for any transformation, should be determined by the students. This can be done through discovery in many of the tasks within this unit. When students make sense of these ideas, discover patterns for each of the three transformations, and discuss them with their peers, they will be less likely to develop these misconceptions and even correct some of them if they already exist. This saves the time of having to reteach much of these concepts again later.

ESSENTIAL QUESTION:

- How can the coordinate plane help me understand properties of reflections, translations and rotations?

MATERIALS:

- Mira™ or reflective mirror or Patty Paper

GROUPING:

- *Individual/Partner*

TASK DESCRIPTION, DEVELOPMENT AND DISCUSSION:

This task is designed to develop a formal definition for rotation.

If students are struggling with the task, teachers may also provide Patty Paper™, wax paper or tracing paper and allow students to rotate the images by fixing a point with a sharp pencil or compass point. Ultimately, students should develop visualization skills and should notice patterns in the coordinates related to 90 degree rotations, which may lead to a discussion of characteristics of perpendicular lines on the coordinate plane in subsequent years.

Another option would be to have students use a MIRA™ or fold paper to verify line of symmetry.

DIFFERENTIATION:

Extension:

- This is an investigation/practice activity that students can complete on the computer. The game, Flip-n-Slide involves reflections, translations, and various lines of reflection. Students may play with a partner or against the computer.
<http://calculationnation.nctm.org/Games/>
- This is an investigation activity students can complete on the computer involving translations. Practice problems are included.
<http://www.mathsisfun.com/geometry/rotation.html>

Intervention:

- Be sure to do several class examples of rotating figures on coordinate planes before starting this task. Have students graph as instructed, then discuss problems 1 & 2 with struggling students before having them do the rest of the task. Prompt struggling students by asking the least helpful question possible in order for students to think for themselves and build their own understanding of reflections and the affect they have on coordinates.

Coordinating Rotations

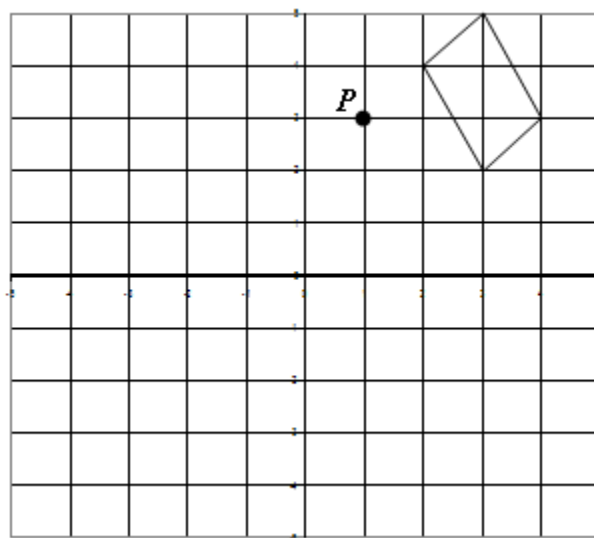

1. Label the coordinates of the polygon above.

(2, 4), (3, 5), (4, 3), and (3, 2)

2. Rotate the polygon 90° (counterclockwise) about the origin and label the coordinates.

The coordinates of the vertices for #2 are (-3, 4), (-5, 3), (-4, 2), and (-2, 3).

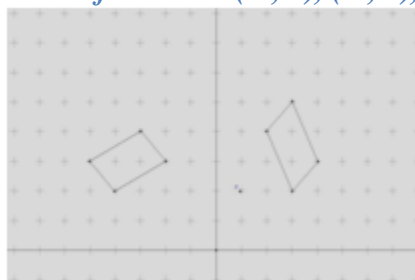

3. Rotate the polygon 90° (clockwise) about the origin and label the coordinates.

The coordinates of the vertices for #3 are (2,-3), (3, -4), (4,-2), and (5, -3).

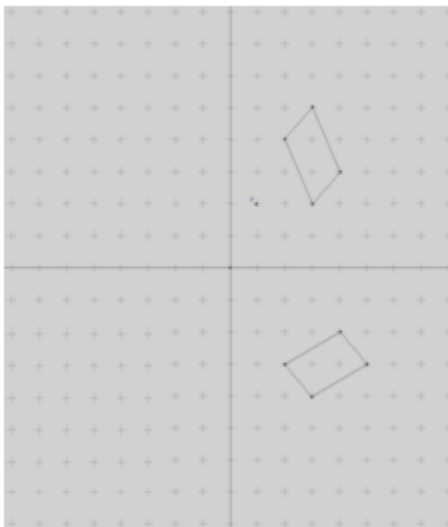

4. Describe a rotation that would guarantee the point P (1, 3) would be inside the square formed by the vertices (5, 5), (-5, 5), (-5,-5), and (5,-5).

Several answers are possible for question 4, including clockwise and counterclockwise rotations. For example, the figure can be rotated 180 degrees counterclockwise about the point (2, 2). It is important that the student description include the center of rotation, the degree measure and direction. Conventionally, positive degree measures are counterclockwise and negative degree measures are clockwise, but teachers may want students to continue using the term “counterclockwise” based on the success of their students.

Coordinating Rotations

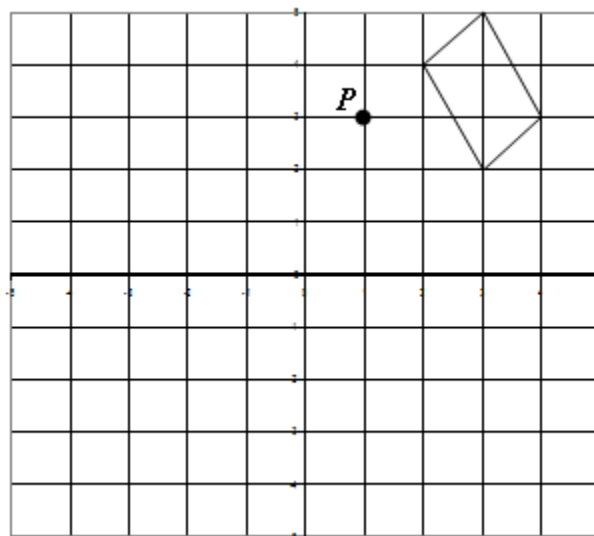

1. Label the coordinates of the polygon above.
2. Rotate the polygon 90° (counterclockwise) about the origin and label the coordinates.
3. Rotate the polygon 90° (clockwise) about the origin and label the coordinates.
4. Describe a rotation that would guarantee the point $P(1, 3)$ would be inside the square formed by the vertices $(5, 5)$, $(-5, 5)$, $(-5, -5)$, and $(5, -5)$.

Representing And Combining Transformations –(FAL)

[Back To Task Table](#)

Source: *Formative Assessment Lesson Materials from Mathematics Assessment Project*
<http://map.mathshell.org/materials/download.php?fileid=1368>

In this lesson, students will practice using transformations.

STANDARDS FOR MATHEMATICAL CONTENT:

Understand congruence and similarity using physical models, transparencies, or geometry software.

MGSE8.G.2 Understand that a two-dimensional figure is congruent to another if the second can be obtained from the first by a sequence of rotations, reflections, and translations; given two congruent figures, describe a sequence that exhibits the congruence between them.

STANDARDS FOR MATHEMATICAL PRACTICE:

This lesson uses all of the practices with emphasis on:

1. Make sense of problems and persevere in solving them
3. Construct viable arguments and critique the reasoning of others.
5. Use appropriate tools strategically

BACKGROUND KNOWLEDGE/TEACHER NOTES:

It may be helpful to check students’ understanding of the vocabulary: congruent, similar, reflections, translations, dilations and rotations as well as find out what they “know” about the effects these transformations have on points in the plane.

In order for students to be successful, students should be confident in their understandings of the following standards:

[MGSE5.G.1](#) [MGSE5.G.2](#) [MGSE6.G.3](#) [MGSE7.G.1](#)

COMMON MISCONCEPTIONS:

The following misconceptions are common among middle school students engaged in this unit:

- *Students often confuse the x and y axis.*
- *Student confuses the terms horizontally and vertically.*
- *Students will need multiple opportunities to explore the transformation of figures so that they can appreciate that points stay the same distance apart and lines stay at the same angle after they have been rotated, reflected, and/or translated.*
- *Student translates rather than reflect the shape.*

- *Some students will mix up clockwise and counterclockwise directions.*
- *Students ignore the center of rotation and rotate the figure from a corner of the shape.*
- *Students often will confuse “rules” for finding coordinates for translations with the rules for rotations, dilations, and reflections.*
- *Students often mis-label corresponding parts of congruent and/or similar figures on the coordinate plane.*
- *Students will need multiple opportunities to explore the transformation of figures in order to make sense of the patterns between the coordinates of the original and the transformed figure.*

In order to prevent or correct these misconceptions, any rules students use to determine coordinates for any transformation, should be determined by the students. This can be done through discovery in many of the tasks within this unit. When students make sense of these ideas, discover patterns for each of the three transformations, and discuss them with their peers, they will be less likely to develop these misconceptions and even correct some of them if they already exist. This saves the time of having to reteach much of these concepts again later.

ESSENTIAL QUESTIONS:

- How can the coordinate plane help me understand properties of reflections, translations, and rotations?
- What is the relationship between reflections, translations, and rotations?

MATERIALS:

- See [source link](#).

GROUPING:

- *Individual/Partner/Small Group*

TASK DESCRIPTION, DEVELOPMENT AND DISCUSSION:

Tasks and lessons from the Mathematics Assessment Project are specifically designed to help teachers effectively formatively assess their students. The way the tasks and lessons are designed gives the teacher a clear understanding of what the students are able to do and not do. Within the lesson, teachers will find suggestions and question prompts that will help guide students towards understanding. For more information access the MAP website:

<http://www.map.mathshell.org/materials/background.php?subpage=formative>

Georgia Department of Education
Georgia Standards of Excellence Framework
GSE Grade 8 • Unit 1

The task, *Representing and Combining Transformations*, is a Formative Assessment Lesson (FAL) that can be found at the website:

<http://map.mathshell.org/materials/lessons.php?taskid=490&subpage=concept>

The FAL document provides a clear lesson design, from the opening of the lesson to the closing of the lesson.

The PDF version of the task can be found at the link below:

<http://map.mathshell.org/materials/download.php?fileid=1368>

Playing With Dilations

[Back to Task Table](#)

In this task, students will investigate the effects of a dilation.

STANDARDS FOR MATHEMATICAL CONTENT:

MGSE8.G.4 Understand that a two-dimensional figure is similar to another if the second can be obtained from the first by a sequence of rotations, reflections, translations, and dilations; given two similar two-dimensional figures, describe a sequence that exhibits the similarity between them.



STANDARDS FOR MATHEMATICAL PRACTICE:

This task uses all of the practices with emphasis on:

1. Make sense of problems and persevere in solving them.
2. Reason abstractly and quantitatively.
4. Model with mathematics.
5. Use appropriate tools strategically.
6. Attend to precision.
7. Look for and make use of structure.

BACKGROUND KNOWLEDGE/TEACHER NOTES:

It may be helpful to check students' understanding of the new vocabulary: congruent, similar, reflections, translations, dilations and rotations as well as find out what they “know” about the effects these transformations have on points and figures in the plane.

In order for students to be successful, students should be confident in their understandings of the following standards:

[MGSE5.G.1](#) [MGSE5.G.2](#) [MGSE6.G.3](#) [MGSE7.G.1](#)

COMMON MISCONCEPTIONS:

The following misconceptions are common among middle school students engaged in this unit:

- *Students often mix up the x and y axis.*
- *Students will need multiple opportunities to explore the transformation of figures so that they can appreciate that points stay the same distance apart and lines stay at the same angle after they have been rotated, reflected, and/or translated.*

- *Students often will confuse “rules” for finding coordinates for dilations with the rules for rotations, translations, and reflections.*
- *Students often mis-label corresponding parts of congruent and/or similar figures on the coordinate plane.*
- *Students will need multiple opportunities to explore the transformation of figures in order to make sense of the patterns between the coordinates of the original and the transformed figure.*

In order to prevent or correct these misconceptions, any rules students use to determine coordinates for any transformation, should be determined by the students. This can be done through discovery in many of the tasks within this unit. When students make sense of these ideas, discover patterns for each of the three transformations, and discuss them with their peers, they will be less likely to develop these misconceptions and even correct some of them if they already exist. This saves the time of having to reteach much of these concepts again later.

ESSENTIAL QUESTIONS:

- What is a dilation and how does this transformation affect a figure in the coordinate plane?
- How can I tell if two figures are similar?

MATERIALS:

- Computer

GROUPING:

- *Individual/Partner*

TASK DESCRIPTION, DEVELOPMENT AND DISCUSSION:

In this task, students will investigate and observe the effects of a dilation with a given center and scale factor. Students should observe that the three lines passing through corresponding vertices of the two triangles intersect at a common point. This point is called the center of dilation. The distance from the center of dilation to the original triangle is reduced or enlarged according to the scale factor. Teachers should support good student dialogue and take advantage of comments and questions to help guide students into correct mathematical thinking.

A possible hook is to use pictures to demonstrate a concrete understanding of dilations. The following pictures can be used to further students’ understanding of similar figures.

- Figure 1 and Figure 2 are similar. Have students explain how they know the pictures are similar.
- Figure 3 and Figure 4 are not similar. Have students explain how they know the pictures are not similar and give the dimensions of a similar picture.
- Figure 5 and figure 6 are not similar. Have students explain how they know the pictures are not similar and give the dimensions of a similar picture.

Another web site where students can play with dilations is the National Library of Virtual Manipulatives (NLVM) site. Below is a direct link to the activities involving dilations.

http://nlvm.usu.edu/en/nav/frames_asid_296_g_4_t_3.html?open=activities

At the NLVM site, students can explore dilations with different shapes. Suggested questions are provided on the NLVM website.

DIFFERENTIATION:

Extension:

- This is an investigation activity students can complete on the computer involving dilations. Dilations are discussed in real-life and practice problems are included.
<http://www.mathsisfun.com/geometry/resizing.html>

Intervention/Scaffolding:

- You may find it useful to do this task with small group and have a group discussion to answer the questions.

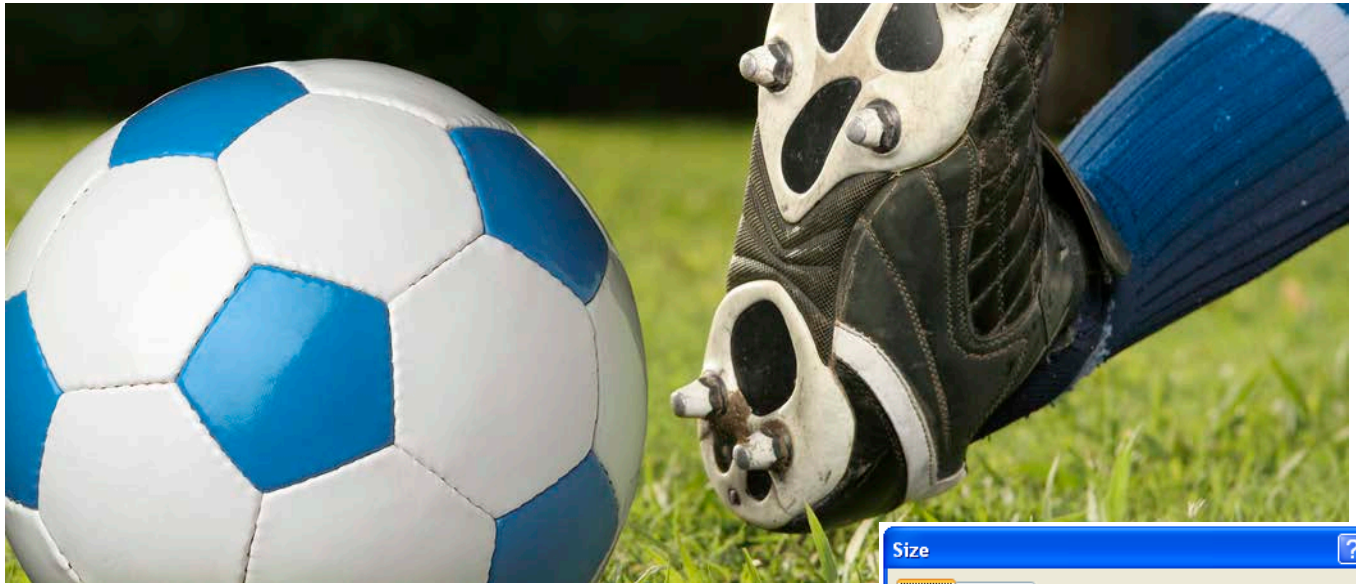

Figure 1

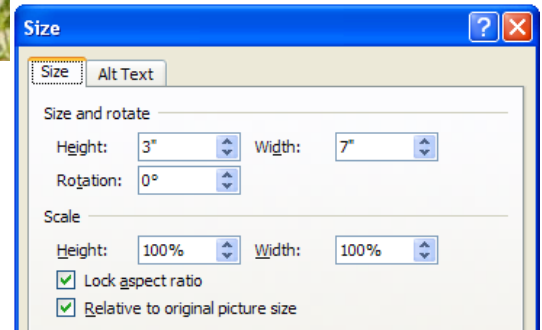

Figure 2

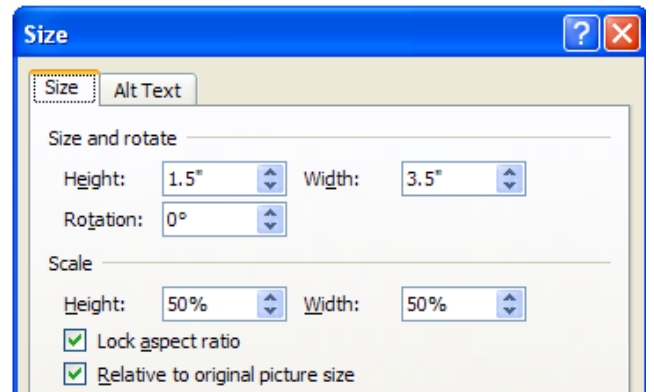

Figure 3



Figure 4



Figure 5



Figure 6

Playing With Dilations

Go to the following website for this investigation:
<http://www.mathsnet.net/dynamic/enlarge2.html>
(Mathsnet is a subscription site)

Click on “Show Values.”



Solutions

- a. Change the scale by moving the red point on the segment in the top left corner. What do you observe when the scale is less than 1? Equal to 1? Greater than 1? As you are changing the scale, observe what is happening to the area of the red triangle and the ratio of the areas of the triangles. Describe what you observe. Why do you think this happens?

The shape of the triangle remains the same. When the scale is less than 1, the red triangle is a reduction of $\triangle ABC$ and is closer to the center of dilation. When the scale is equal to 1, the red triangle is congruent to $\triangle ABC$. When the scale is greater than 1, the red triangle is an enlargement of $\triangle ABC$ and is further away from the center of dilation. The distance from X to a vertex of the red triangle depends on the scale factor (e.g., if the scale factor is 0.5, the distance from X to a vertex of the red triangle is $\frac{1}{2}$ the distance from X to the corresponding vertex on the blue triangle).

As the scale increases, the area of the red triangle increases because increasing the scale makes the red triangle larger. The ratio of the area of the red triangle to the blue triangle also increases because the numerator of the fraction representing the ratio is getting larger.

[Note to teachers: Some students might observe that the ratio of the areas of the triangles is the square of the scale factor. This might not be obvious unless students look at the ratio for scale factors such as 0.5 or 2. This concept will be encountered in other activities, so it is not essential that students make this observation at this point.]

- b. Move the point X to different locations outside, inside, and on the triangle. What changes in the values do you notice as you move X ? Explain why you think this happens.

The values do not change because the scale and the areas of the triangles are not changing. The only thing that changes is the location of X and the red triangle in relationship to the blue triangle.

- c. As you moved X in part b, other than the values, describe all the changes you noticed. Why do you think these changes occurred?

The lines through the corresponding vertices of the red triangle and $\triangle ABC$ always intersect at a common point, X . [Teachers may want to tell students that this common point is called the center of dilation.]

- d. What are some real-world situations in which this might be used?

Projecting something on a screen (e.g., using an overhead projector), reducing or enlarging pictures, scale drawings (e.g., maps, building plans). Students may remember something about scale drawings from previous grades.

Playing With Dilations

Go to the following website for this investigation:

<http://www.mathsnet.net/dynamic/enlarge2.html>

(Mathsnet is a subscription site)

Click on “Show Values.”



- a. Change the scale by moving the red point on the segment in the top left corner. What do you observe when the scale is less than 1? Equal to 1? Greater than 1? As you are changing the scale, observe what is happening to the area of the red triangle and the ratio of the areas of the triangles. Describe what you observe. Why do you think this happens?
- b. Move the point X to different locations outside, inside, and on the triangle. What changes in the values do you notice as you move X ? Explain why you think this happens.
- c. As you moved X in part b, other than the values, describe all the changes you noticed. Why do you think these changes occurred?
- d. What are some real-world situations in which this might be used?

Similar Triangles

[Back to Task Table](#)

In this task, students will discover the relationships that exist between similar figures.

STANDARDS OF MATHEMATICAL CONTENT:

MGSE8.G.4 Understand that a two-dimensional figure is similar to another if the second can be obtained from the first by a sequence of rotations, reflections, translations, and dilations; given two similar two-dimensional figures, describe a sequence that exhibits the similarity between them.

MGSE8.G.5 Use informal arguments to establish facts about the angle sum and exterior angle of triangles, about the angles created when parallel lines are cut by a transversal, and the angle-angle criterion for similarity of triangles. *For example, arrange three copies of the same triangle so that the three angles appear to form a line, and give an argument in terms of transversals why this is so.*

STANDARDS FOR MATHEMATICAL PRACTICE:

This task uses all of the practices with emphasis on:

1. Make sense of problems and persevere in solving them.
2. Reason abstractly and quantitatively.
3. Construct viable arguments and critique the reasoning of others.
4. Model with mathematics.
5. Use appropriate tools strategically.
6. Attend to precision.
7. Look for and make use of structure.

BACKGROUND KNOWLEDGE/TEACHER NOTES:

It may be helpful to check students' understanding of the new vocabulary: similar, congruent, reflections, translations, dilations and rotations as well as find out what they "know" about the effects these transformations have on points and figures in the plane.

In order for students to be successful, students should be confident in their understandings of the following standards:

[MGSE5.G.1](#) [MGSE5.G.2](#) [MGSE6.G.3](#) [MGSE7.G.1](#)

COMMON MISCONCEPTIONS:

The following misconceptions are common among middle school students engaged in this unit:

- *Students often mix up the x and y axis.*
- *Students will need multiple opportunities to explore the transformation of figures so that they can appreciate that points stay the same distance apart and lines stay at the same angle after they have been rotated, reflected, and/or translated.*
- *Students often will confuse “rules” for finding coordinates for dilations with the rules for rotations, translations, and reflections.*
- *Students often mis-label corresponding parts of congruent and/or similar figures on the coordinate plane.*
- *Some students will continue to have trouble writing and solving ratios.*
- *Students will need multiple opportunities to explore the transformation of figures in order to make sense of the patterns between the coordinates of the original and the transformed figure.*

In order to prevent or correct these misconceptions, any rules students use to determine coordinates for any transformation, should be determined by the students. This can be done through discovery in many of the tasks within this unit. When students make sense of these ideas, discover patterns for each of the three transformations, and discuss them with their peers, they will be less likely to develop these misconceptions and even correct some of them if they already exist. This saves the time of having to reteach much of these concepts again later.

ESSENTIAL QUESTIONS:

- What is a dilation and how does this transformation affect a figure in the coordinate plane?
- How can I tell if two figures are similar?
- Under what conditions are similar figures congruent?

MATERIALS:

- graph paper
- colored pencils

GROUPING:

- *Individual/Partner/Small Group*

TASK DESCRIPTION, DEVELOPMENT AND DISCUSSION:

In this task, students will discover the relationships that exist between similar figures using the scale factors, length ratios, and area ratios. Teachers should support good student dialogue and take advantage of comments and questions to help guide students into correct mathematical thinking.

This is a great opportunity for students to use what they have learned concerning the fact that there are 180 degrees in a triangle and the standards concerning similar figures.

Have students use a MIRA™ or fold paper to verify line of symmetry.

DIFFERENTIATION:

Extension:

- The following site allows for students to view in real time the effects of changing the scale factor on a triangle. <https://www.desmos.com/calculator/elccqxyf4w> This can be very useful for students to make observations and notice of the patterns involved in similar figures.
- This is an investigation activity students can complete on the computer involving similar triangles. Similar Triangles are discussed in real-life and practice problems are included. <http://www.mathsisfun.com/geometry/triangles-similar.html>

Intervention:

- The following site allows for students to view in real time the effects of changing the scale factor on a triangle. <https://www.desmos.com/calculator/elccqxyf4w> This can be very useful for students to make observations and notice of the patterns involved in similar figures.

Similar Triangles

1. The sketch below shows two triangles, $\triangle ABC$ and $\triangle EFG$. $\triangle ABC$ has an area of 12 square units, and its base (AB) is equal to 8 units. The base of $\triangle EFG$ is equal to 24 units.

Comment

Students need to realize that the scale factor is 3.

- a. How do you know that the triangles are similar?

The triangles are similar because the smaller triangle can be reflected and then dilated by a factor of three to be the larger triangle. This could be demonstrated with Geometer's Sketchpad.

- b. Name the pairs of corresponding sides and the pairs of corresponding angles. How are the corresponding sides related and how are the corresponding angles related? Why is this true?

*AB and EF ; BC and FG ; AC and EG are the corresponding sides
 $\angle B$ and $\angle F$; $\angle C$ and $\angle G$; $\angle A$ and $\angle E$ are the corresponding angles*

$$\frac{AB}{EF} = \frac{BC}{FG} = \frac{AC}{EG}$$

$$m\angle B = \angle F; m\angle C = m\angle G; m\angle A = m\angle E$$

These relationships are true because the triangles are similar.

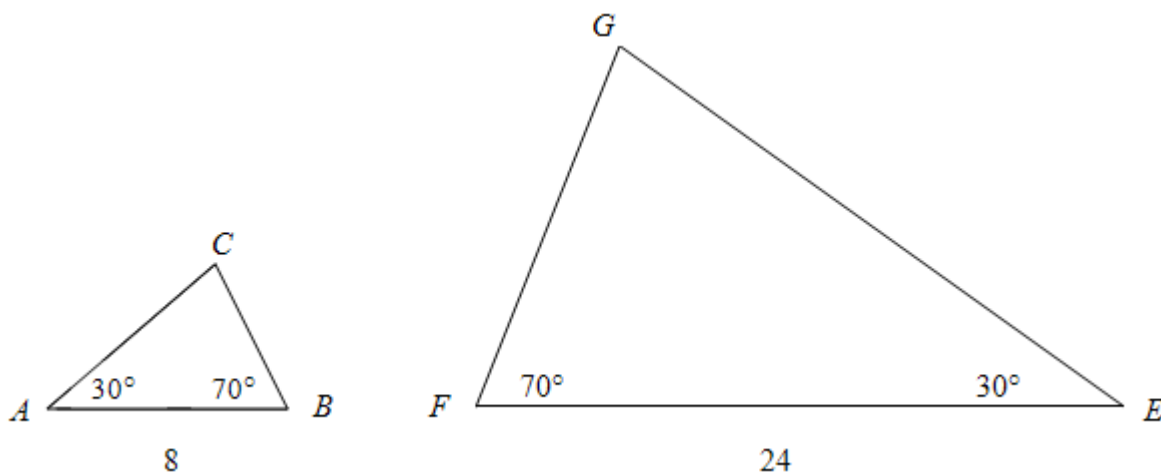

2. The sketch below shows two triangles, $\triangle MNO$ and $\triangle PQR$.

- a. How do you know that the triangles are similar?

The triangles are similar because the smaller triangle can be rotated and then dilated by a factor of $\frac{3}{2}$ to be the larger triangle. This could be demonstrated with Geometer's Sketchpad.

- b. Name the pairs of corresponding sides and the pairs of corresponding angles. How are the corresponding sides related and how are the corresponding angles related? Why is this true?

*MO and QR; ON and RP; NM and PQ are the corresponding sides
 $\angle M$ and $\angle Q$; $\angle O$ and $\angle R$; $\angle N$ and $\angle P$ are the corresponding angles*

$$\frac{MO}{QR} = \frac{ON}{RP} = \frac{NP}{PQ}$$

$$m\angle M \cong \angle Q; m\angle O \cong m\angle R; m\angle N \cong m\angle P$$

These relationships are true because the triangles are similar.

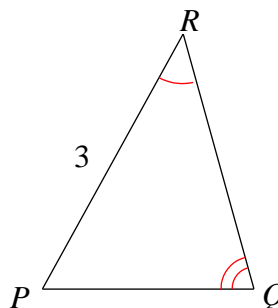
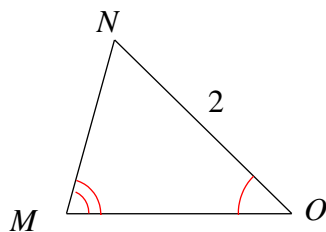

3. The sketch below shows two triangles, $\triangle XYZ$ and $\triangle HFG$.

- a. How do you know that the triangles are similar?

The triangles are similar because the smaller triangle can be dilated to be the larger triangle. This could be demonstrated with Geometer's Sketchpad.

- b. Name the pairs of corresponding sides and the pairs of corresponding angles. How are the corresponding sides related and how are the corresponding angles related? Why is this true?

*XY and HF; YZ and FG; ZX and GH are the corresponding sides
 $\angle X$ and $\angle H$; $\angle Y$ and $\angle F$; $\angle Z$ and $\angle G$ are the corresponding angles*

$$\frac{XY}{HF} = \frac{YZ}{FG} = \frac{ZX}{GH}$$

$$m\angle X \cong \angle H; m\angle Y \cong m\angle F; m\angle Z \cong m\angle G$$

These relationships are true because the triangles are similar.

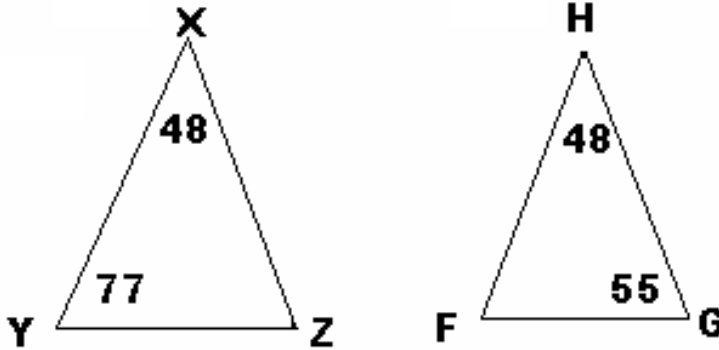

4. The sketch below shows two triangles, $\triangle LMN$ and $\triangle FEG$.
- a. How do you know that the triangles are similar? Is there anything else you can say about the two triangles?

The triangles are similar because $\triangle LMN$ can be rotated, reflected, and translated to be $\triangle FEG$. This could be demonstrated with Geometer's Sketchpad. Since the scale factor is 1 the triangles are also congruent.

- b. Name the pairs of corresponding sides and the pairs of corresponding angles. How are the corresponding sides related and how are the corresponding angles related? Why is this true?

*LM and FG; MN and GE; NL and EF are the corresponding sides
 $\angle L$ and $\angle F$; $\angle M$ and $\angle G$; $\angle N$ and $\angle E$ are the corresponding angles*

$$LM = FG; MN = GE; NL = EF$$

$$m\angle L \cong \angle F; m\angle M \cong m\angle G; m\angle N \cong m\angle E$$

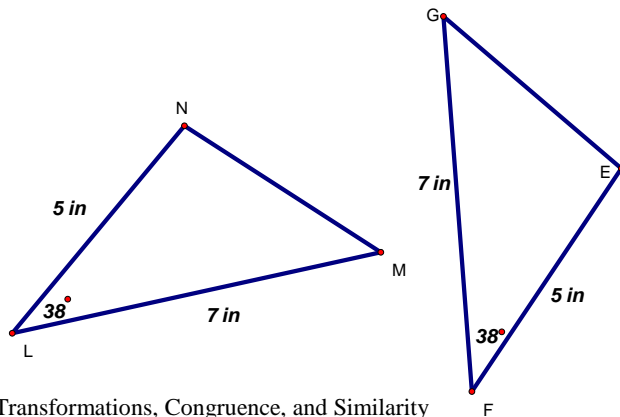

Similar Triangles

- The sketch below shows two triangles, $\triangle ABC$ and $\triangle EFG$. $\triangle ABC$ has an area of 12 square units, and its base (AB) is equal to 8 units. The base of $\triangle EFG$ is equal to 24 units.
 - How do you know that the triangles are similar?
 - Name the pairs of corresponding sides and the pairs of corresponding angles. How are the corresponding sides related and how are the corresponding angles related? Why is this true?

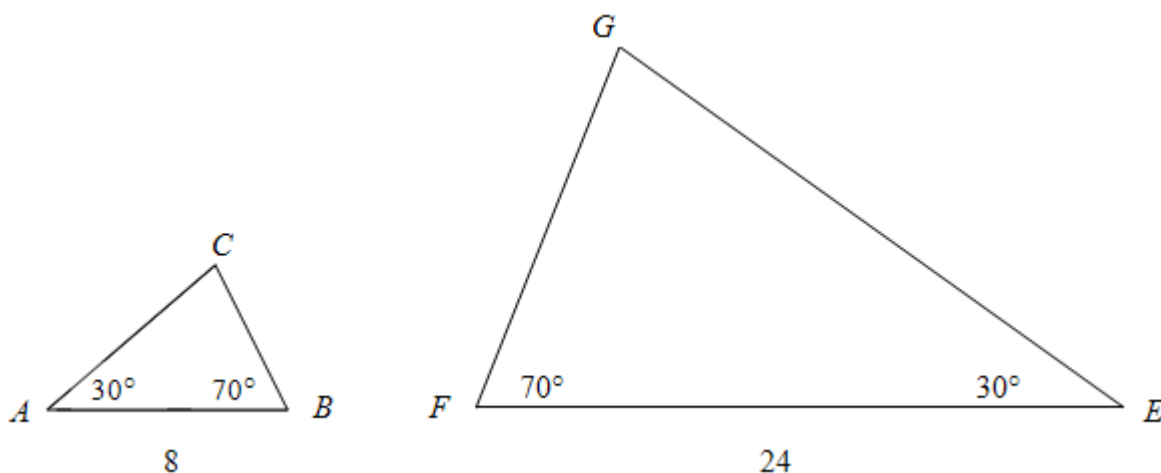

- The sketch below shows two triangles, $\triangle MNO$ and $\triangle PQR$.
 - How do you know that the triangles are similar?
 - Name the pairs of corresponding sides and the pairs of corresponding angles. How are the corresponding sides related and how are the corresponding angles related? Why is this true?

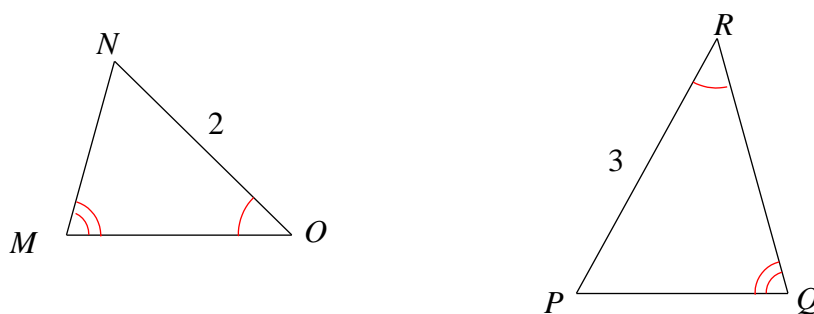

3. The sketch below shows two triangles, $\triangle XYZ$ and $\triangle HFG$.
- How do you know that the triangles are similar?
 - Name the pairs of corresponding sides and the pairs of corresponding angles. How are the corresponding sides related and how are the corresponding angles related? Why is this true?

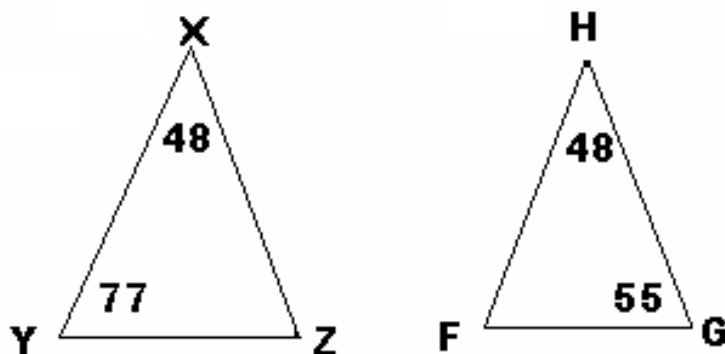

4. The sketch below shows two triangles, $\triangle LMN$ and $\triangle FEG$.
- How do you know that the triangles are similar? Is there anything else you can say about the two triangles?
 - Name the pairs of corresponding sides and the pairs of corresponding angles. How are the corresponding sides related and how are the corresponding angles related? Why is this true?

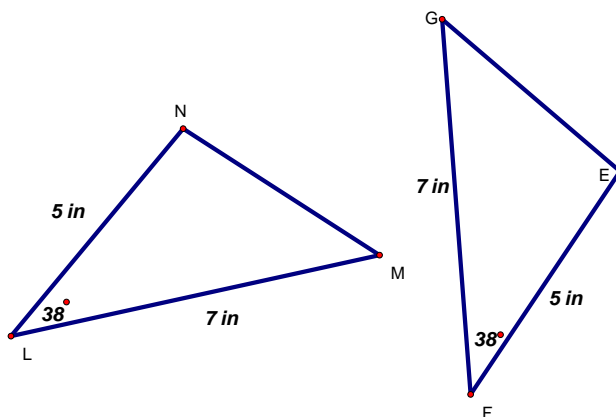

Tessellating Triangles (Spotlight Task)

[Back to Task Table](#)

STANDARDS FOR MATHEMATICAL CONTENT:

MGSE8.G.5 Use informal arguments to establish facts about the angle sum and exterior angle of triangles, about the angles created when parallel lines are cut by a transversal, and the angle-angle criterion for similarity of triangles. *For example, arrange three copies of the same triangle so that the three angles appear to form a line, and give an argument in terms of transversals why this is so.*

STANDARDS FOR MATHEMATICAL PRACTICE:

1. Make sense of problems and persevere in solving them.
2. Reason abstractly and quantitatively.
3. Construct viable arguments and critique the reasoning of others.
4. Model with mathematics.
5. Use appropriate tools strategically.
6. Attend to precision.
7. Look for and make use of structure.
8. Look for and express regularity in repeated reasoning.

ESSENTIAL QUESTIONS:

- When I draw a transversal through parallel lines, what are the special angle and segment relationships that occur?
- Why do I always get a special angle relationship when any two lines intersect?
- How can I be certain whether lines are parallel, perpendicular, or skew lines?

MATERIALS REQUIRED:

- Card stock or index cards
- Pencil
- Paper
- Straight edge
- Scissors
- Markers, colored pencils or crayons
- Angle ruler or protractor (optional)
- Set of Geo-Stix (optional)

TIME NEEDED:

- 1 to 2 class periods

• **BACKGROUND KNOWLEDGE/TEACHER NOTES:**

This task is meant to be very open in the beginning and middle. The conclusions reached by students at the end will need to be guided by the teacher, since it is highly unlikely that students will spontaneously spout out the mathematical vocabulary (i.e. alternate interior angles, vertical angles, etc.) as they share their findings. This task is most effective when students (either in pairs or individually) create their own triangle using a straight edge. The conclusions they reach are much more powerful when this is the case.

Prior to assigning this task, it is best to show students some tessellations of other shapes and discuss what it means to tessellate a plane:

Regular Tessellations:

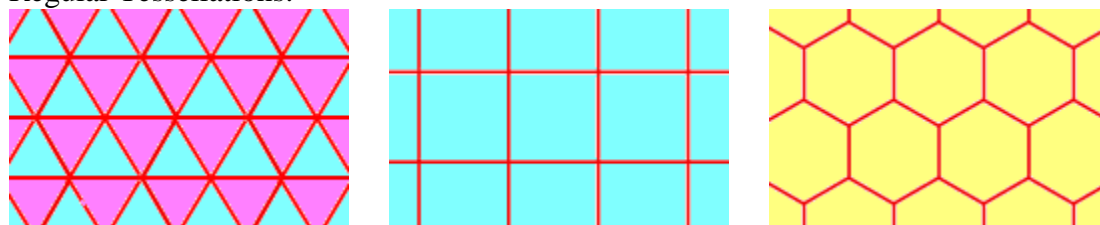

Semi-Regular Tessellations:

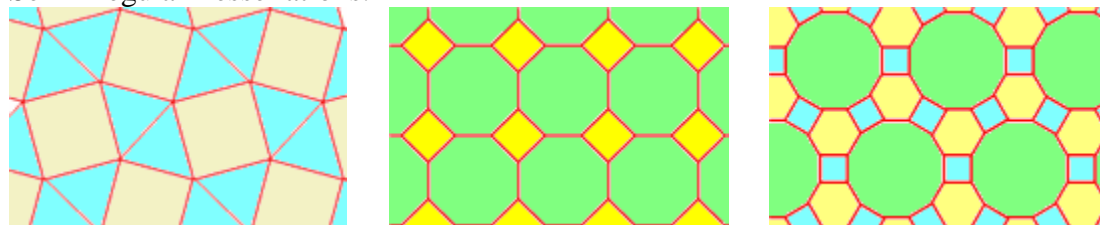

Make notes of what students share. You will likely hear some of the following:

- There are no gaps
- Some of the shapes are turned (rotated) upside down.
- How come some shapes can't tessellate by themselves?
- Are there only 3 regular tessellations?

Of course this is not an exhaustive list. The key ideas that we should look for are that there are no gaps and that some shapes have to be rotated in order to tessellate a plane. Inform students that they will be tessellating a plane. The goal is to look for some structure in the tessellation they create. They should keep their eyes open for patterns and think of reasons to explain those patterns.

Directions for Tessellating Triangles:

1. On an index card, use a straight edge and a pencil to construct a triangle. It can be any kind of triangle you like.

Mathematics • GSE Grade 8 • Unit 1: Transformations, Congruence, and Similarity

Richard Woods, State School Superintendent

July 2016 • Page 78 of 119

All Rights Reserved

2. Cut it out.
3. Color each angle a different color.
4. Trace it on your paper near the lower left hand corner.
5. Color the corresponding angles of the traced triangle the same as the original.
6. Tessellate the paper from there, coloring the corresponding angles the same as the original as you go.
7. Write down what you notice as well as any conclusions you can draw from what you notice.

After tessellating their paper and drawing conclusions about what they notice, have students share their discoveries. This is very powerful for students, since they are essentially giving you definitions that we normally give them. At this point, all they need is the mathematical term to match it. Below is a list of some observations made by students after completing this task:

1. The sum of the angles of any triangle equals 180° .
2. The sum of the angles of any quadrilateral is 360° .
3. The sum of the angles of any polygon is $(n-2)180^\circ$.
4. The opposite angles of a parallelogram are always **equal**.
5. Angle size is the same in similar figures.
6. Circles are 360° .
7. **Vertical angles** are **equal**.
8. **Alternate interior angles** are **equal**.
9. **Alternate exterior angles** are **equal**.
10. **Corresponding angles** are **equal**.
11. **Supplements** of the same angle are **equal**.
12. An **exterior angle** of a triangle is equal to the sum of the two **non-adjacent interior angles**.
13. All triangles will **tessellate**.
14. **Diagonals** in a parallelogram **cut in half**.
15. The diagonal of a parallelogram divides it into two congruent triangles.

Vocabulary in bold were unknown to students prior to the task. Yellow highlighted words were used by students. The correct terms were introduced or reintroduced to students at the time of the statement. Students' use of the correct terms (congruent and bisected) dramatically increased afterward. Green highlighted words were not used by students, but I can't remember the words students used.

DIFFERENTIATION:

Extension:

- For students requiring an extension, have them investigate other tessellations, such as those that require more than one shape and look for patterns there as well. Can they draw some of the same conclusions? Are there other mathematical ideas that can be investigated here as well?

Intervention:

- For students in need of support, give guidance as they tessellate their triangle. For some this can be extremely frustrating, especially if students have not had a chance to investigate other tessellations prior to beginning this task.

Tessellating Triangles (Spotlight Task)

Directions for Tessellating Triangles:

1. On an index card, use a straight edge and a pencil to construct a triangle. It can be any kind of triangle you like.
 2. Cut it out.
 3. Color each angle a different color.
 4. Trace it on your paper near the lower left hand corner.
 5. Color the corresponding angles of the traced triangle the same as the original.
 6. Tessellate the paper from there, coloring the corresponding angles the same as the original as you go.
 7. Write down what you notice as well as any conclusions you can draw from what you notice.
-

Directions for Tessellating Triangles:

1. On an index card, use a straight edge and a pencil to construct a triangle. It can be any kind of triangle you like.
 2. Cut it out.
 3. Color each angle a different color.
 4. Trace it on your paper near the lower left hand corner.
 5. Color the corresponding angles of the traced triangle the same as the original.
 6. Tessellate the paper from there, coloring the corresponding angles the same as the original as you go.
 7. Write down what you notice as well as any conclusions you can draw from what you notice.
-

Directions for Tessellating Triangles:

1. On an index card, use a straight edge and a pencil to construct a triangle. It can be any kind of triangle you like.
2. Cut it out.
3. Color each angle a different color.
4. Trace it on your paper near the lower left hand corner.
5. Color the corresponding angles of the traced triangle the same as the original.
6. Tessellate the paper from there, coloring the corresponding angles the same as the original as you go.
7. Write down what you notice as well as any conclusions you can draw from what you notice.

Transversals, Tape, And Stickies!

[Back to Task Table](#)

Source: Andrew Stadel <http://mr-stadel.blogspot.com/2012/10/transversals-tape-and-stickies.html>

In this task, students will reinforce their understanding of angle relationships of intersecting and parallel/transversal lines.

STANDARDS FOR MATHEMATICAL CONTENT:

MGSE8.G.5 Use informal arguments to establish facts about the angle sum and exterior angle of triangles, about the angles created when parallel lines are cut by a transversal, and the angle-angle criterion for similarity of triangles. *For example, arrange three copies of the same triangle so that the three angles appear to form a line, and give an argument in terms of transversals why this is so.*

STANDARDS FOR MATHEMATICAL PRACTICE:

This task uses all of the practices with emphasis on:

1. Make sense of problems and persevere in solving them.
2. Reason abstractly and quantitatively.
3. Construct viable arguments and critique the reasoning of others.
6. Attend to precision.
7. Look for and make use of structure.

BACKGROUND KNOWLEDGE/TEACHER NOTES:

After students investigate parallel lines and the angle pairs formed when these lines are cut by a transversal (as in the previous task), it's important that they have some purposeful practice and time to discuss their sense making with others. This is a time for students to try to clear up their own misconceptions through discourse with teacher facilitation.

COMMON MISCONCEPTIONS:

Students who have not had to make sense of quantities in geometry tend to have trouble remembering information and concepts such as:

- *A line has a measure of 180 degrees.*
- *The sum of the angles in a triangle is 180 degrees.*
- *When two parallel lines are cut by a transversal, certain angle pairs are congruent and others are supplementary*

In order for students to solidify their understanding, they need to share their ideas with other students – some of whom may also have some misconceptions. They need to share these ideas in

a safe place, where they know they can learn from their mistakes, while solving problems worth solving.

The puzzle like problem in this task offer students a chance to truly engage in SMP 1, 2, 3, 6 and 7.

ESSENTIAL QUESTIONS:

- When I draw a transversal through parallel lines, what are the special angle and segment relationships that occur?
- Why do I always get a special angle relationship when any two lines intersect?

MATERIALS:

- Copy of the task (recording sheet optional)
- Tape
- Sticky Notes (Extra Sticky works best)

GROUPING:

- Small Group (no more than 4 per group works best)

TASK DESCRIPTION, DEVELOPMENT AND DISCUSSION:

This task is designed to reinforce student understanding of angle relationships when lines intersect and when a transversal crosses parallel lines. Using geometric properties of intersecting and parallel lines to establish and reinforce algebraic relationships is an almost limitless and rich source of problems for student practice and connections between mathematical concepts.

Review the previous task and the angle relationships discovered when two parallel lines are cut by a transversal.

Introduce the task by presenting the set-up on the walls to students (a sample is shown below):



Group students and give them a copy of the handout to guide their work. Instruct students to begin with the two parallel lines and the transversal due to its lower entry point.

Students are to place the numbered stickies on the masking tape diagram so that they match the clues on the handout.

When students are satisfied with their solutions, have them write in their journals or notebooks about their experience solving the puzzles. Take note of the groups' work and ask several students to share their "I'm sures" with the class. If anyone disagrees, allow them to share. Promote as much student discourse as possible here without giving away solutions. This is where understanding is developed.

The goal of this task is for students to use their own understandings of angle relationships formed by two parallel lines cut by a transversal to determine where certain angles must be placed on a diagram. Once the discussion of student answers is complete, don't be surprised if students are satisfied with their answers and "don't need" to be confirmed by the teacher.

DIFFERENTIATION:

Extension:

Students in need of extensions to this task, may be asked to look for specific relationships between angles formed by two non-parallel lines cut by a transversal. For example: For the three intersecting lines in this task, 5 and 2 are alternate exterior angles. Do the angle measures have a specific relationship? What would happen if the lines were rearranged a bit? Would it change the relationship? How can you tell? Be prepared to share your findings.

Intervention:

Students may need to investigate angles, parallel lines, and polygons to determine relationships using tools such as a protractor, turn measurer, or other angle measuring device. For these students, the following mini-lessons may be used in small groups or even as a whole class prior to some of the other tasks in this unit. <http://nzmaths.co.nz/resource/angles-parallel-lines-and-polygons>

Transversals, Tape, And Stickies! -

Parallel Lines

Angles	Relationship
1, 2	Alternate Interior angles
3, 4	Alternate Exterior angles
6, 7	Alternate Exterior angles
6, 8	Corresponding angles
1, 3	Vertical angles
2, 5	Same-side Interior angles
2, 8	Linear Pair

3 Intersecting Lines

Angles	Relationship
3, 1	Alternate Interior angles
1, 10	Same-side Interior angles
5, 1	Vertical angles
2, 10	Linear Pair
5, 2	Alternate Exterior angles
10, 11	Corresponding angles
11, 1	Alternate Interior angles
10, 12	Corresponding angles
9, 6	Corresponding angles
9, 11	Vertical angles
7, 3	Alternate Exterior angles
2, 3	Vertical angles
8, 3	Same-side Interior angles

Recording Sheet

Parallel Lines

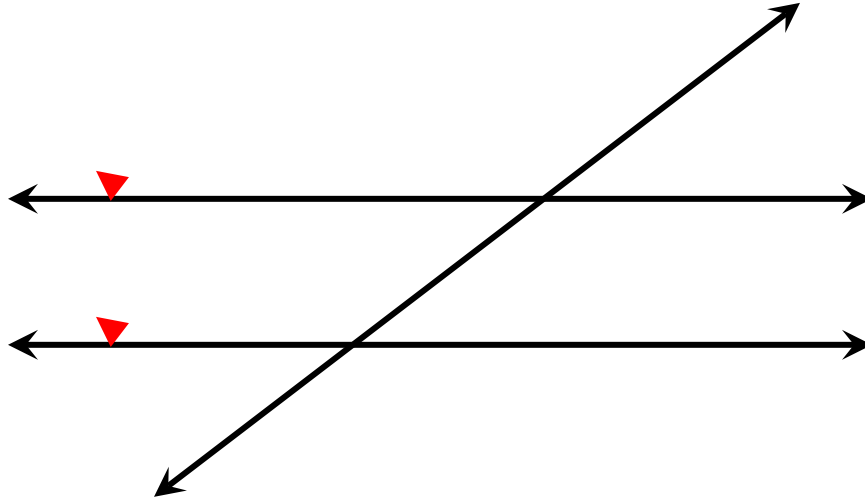

Intersecting Lines

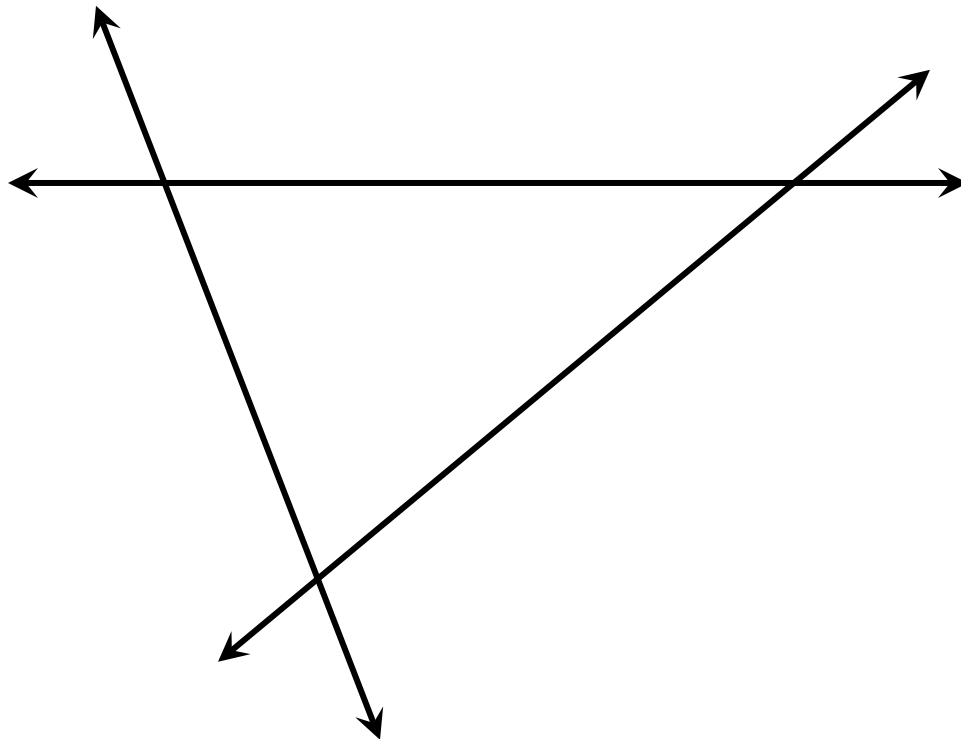

Lunch Lines

[Back to Task Table](#)

In this task, students will reinforce understanding of angle relationships of intersecting and parallel/transversal lines.

STANDARDS FOR MATHEMATICAL CONTENT:

MGSE8.G.5 Use informal arguments to establish facts about the angle sum and exterior angle of triangles, about the angles created when parallel lines are cut by a transversal, and the angle-angle criterion for similarity of triangles. *For example, arrange three copies of the same triangle so that the three angles appear to form a line, and give an argument in terms of transversals why this is so.*

STANDARDS FOR MATHEMATICAL PRACTICE:

This task uses all of the practices with emphasis on:

1. Make sense of problems and persevere in solving them.
2. Reason abstractly and quantitatively.
3. Construct viable arguments and critique the reasoning of others.
4. Model with mathematics.
5. Use appropriate tools strategically.
6. Attend to precision.
7. Look for and make use of structure.

BACKGROUND KNOWLEDGE/TEACHER NOTES:

After students investigate parallel lines and the angle pairs formed when these lines are cut by a transversal (as in the previous task), it's important that they have some purposeful practice and time to discuss their sense making with others. This is a time for students to try to clear up their own misconceptions through discourse with teacher facilitation.

COMMON MISCONCEPTIONS:

Common misconceptions with angle relationships among 8th grade students include:

- *being unsure of how many degrees in a straight line.*
- *confusing one angle relationship for another*

Misconceptions arise for multiple reasons and can actually be an important part of learning mathematics. When mathematical misconceptions are not caught soon enough, they can cause some real problems. In order to avoid these festering misconceptions, students must be given time to make sense of the mathematics they are learning. When students are asked to rush through their learning without understanding for themselves, misconceptions arise. Without

reasoning to back up the answers they give, these misconceptions can remain hidden for a long time. When these misconceptions are found, often weeks or months (even years) later, they are very difficult to correct.

Time is best spent up front, allowing students to build their own understandings with teachers asking questions beginning with “How” and “Why,” to diagnose and treat the misconceptions as soon as possible.

ESSENTIAL QUESTIONS:

- When I draw a transversal through parallel lines, what are the special angle and segment relationships that occur?
- Why do I always get a special angle relationship when any two lines intersect?

MATERIALS:

- Copy of the task
- Straws, tape, projector (all optional)

GROUPING:

- Individual/Partner/Small Group

TASK DESCRIPTION, DEVELOPMENT AND DISCUSSION:

This task is designed to reinforce student understanding of angle relationships when lines intersect and when a transversal crosses parallel lines. Using geometric properties of intersecting and parallel lines to establish and reinforce algebraic relationships is an almost limitless and rich source of problems for student practice and connections between mathematical concepts.

Have students use a MIRA™ or fold paper to verify line of symmetry.

DIFFERENTIATION:

Extension:

- Create another straw design similar to Justin’s design. Create it in a way that the lines would be parallel. You may not simply adjust the numbers on his design. You must come up with your own original algebra expressions to represent the given angles. Then, on a separate sheet of paper, show your work and prove that your design includes parallel lines. You will trade designs with a partner to check their work.

Intervention:

- Have students use protractors and straws to recreate Paul’s and Jane’s straw designs prior to solving these problems. After the students solve the problems, have them measure the angles with their protractors to verify their results.

Lunch Lines

Paul, Jane, Justin, Sarah, and Opal were finished with lunch and began playing with drink straws. Each one was making a line design using either 3 or 4 straws. They had just come from math class where they had been studying special angles. Paul pulled his pencil out of his book bag and labeled some of the angles and lines. He then challenged himself and the others to find all the labeled angle measurements and to determine whether the lines that appear to be parallel really could be parallel.

Paul's straw design

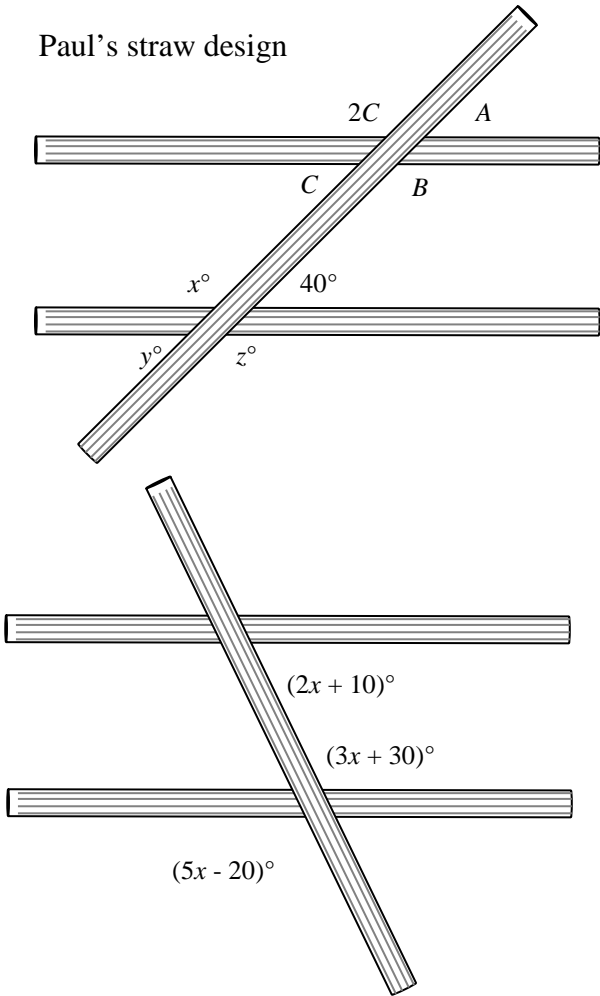

Jane's straw design

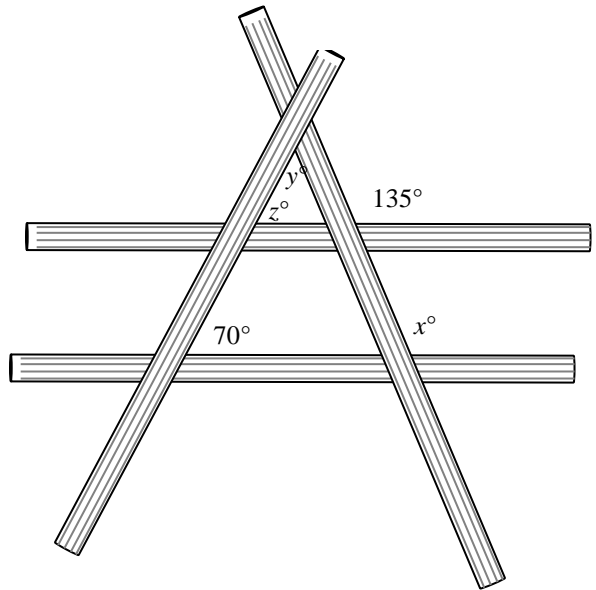

- Find all of the labeled angle measurements, assuming the lines that appear parallel are parallel.
- Determine whether the lines that appear to be parallel really could be parallel.
- Explain the reasoning for your results.

Justin's straw design

Solutions

Paul's straw design:

This relies entirely on vertical angles and linear pairs. $m\angle x = m\angle z = 140^\circ$; $m\angle y = 40^\circ$. Use the linear pair relationship for the angles involving C to conclude $m\angle A = m\angle C = 40^\circ$; $m\angle B \neq m\angle 2C$; $m\angle C + m\angle 2C \neq 180^\circ$. Therefore, lines m and n are not parallel because corresponding angles do not have the same measure.

NOTE: The argument could also be made because neither alternate interior nor alternate exterior angles are congruent. Also, neither same-side interior nor exterior angles are supplementary.

Jane's straw design:

Use corresponding, same-side interior, and vertical angles; linear pairs; and the sum of the angles in a triangle. $m\angle x = 135^\circ$, $m\angle z = 70^\circ$, $m\angle y = 65^\circ$

Justin's straw design:

Vertical angles give $5x - 20 = 3x + 30$

$$\begin{array}{r} \underline{-3x} \quad \underline{-3x} \\ 2x - 20 = 30 \\ \underline{+20} \quad \underline{+20} \\ 2x = 50 \\ 2x \div 2 = 50 \div 2 \\ x = 25 \end{array}$$

If the lines are parallel, then the same-side interior angles must have a sum of 180° .

$$\begin{aligned} \text{By substitution, } (2x + 10) + (3x + 30) &= (2 \cdot 25 + 10) + (3 \cdot 25 + 30) \\ &= (50 + 10) + (75 + 30) \\ &= 60 + 105 \\ &\neq 180 \end{aligned}$$

Since these measures are not supplementary, the lines are not parallel.

Lunch Lines

Paul, Jane, Justin, Sarah, and Opal were finished with lunch and began playing with drink straws. Each one was making a line design using either 3 or 4 straws. They had just come from math class where they had been studying special angles. Paul pulled his pencil out of his book bag and labeled some of the angles and lines. He then challenged himself and the others to find all the labeled angle measurements and to determine whether the lines that appear to be parallel really could be parallel.

Paul's straw design

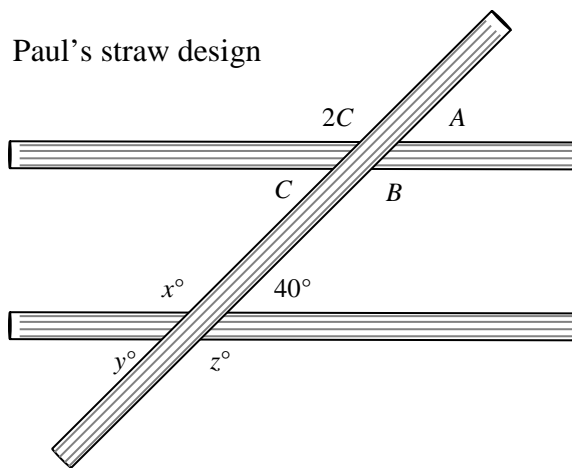

Jane's straw design

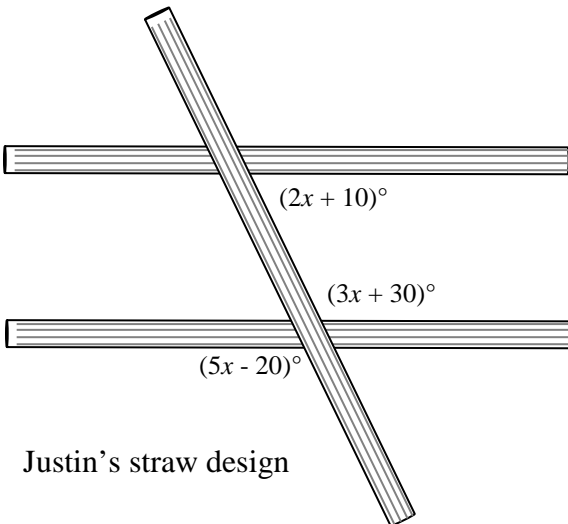
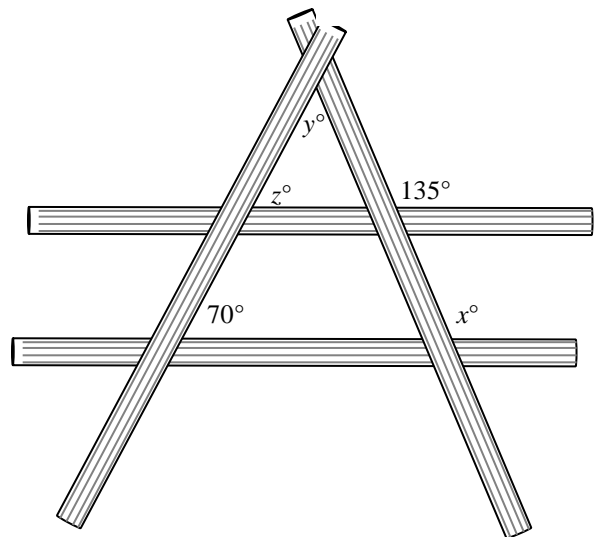

Justin's straw design

- Find all of the labeled angle measurements, assuming the lines that appear parallel are parallel.
- Determine whether the lines that appear to be parallel really could be parallel.
- Explain the reasoning for your results.

For The Win! (Spotlight Task)

[Back to Task Table](#)

STANDARDS FOR MATHEMATICAL CONTENT:

MGSE8.G.5 Use informal arguments to establish facts about the angle sum and exterior angle of triangles, about the angles

STANDARDS FOR MATHEMATICAL PRACTICE:

1. Make sense of problems and persevere in solving them.
2. Reason abstractly and quantitatively.
3. Construct viable arguments and critique the reasoning of others.
4. Model with mathematics.
5. Use appropriate tools strategically.
6. Attend to precision.

ESSENTIAL QUESTIONS:

- When I draw a transversal through parallel lines, what are the special angle and segment relationships that occur?
- Why do I always get a special angle relationship when any two lines intersect?

MATERIALS REQUIRED:

- Students recording sheet (pool table) for part 1 and 2
- <http://vimeo.com/98829715>
- Tennis balls, ping pong balls, marbles, etc...

BACKGROUND KNOWLEDGE/TEACHER NOTES:

After students investigate parallel lines and the angle pairs formed when these lines are cut by a transversal (as in the previous tasks), it's important that they have some purposeful practice and time to discuss their sense making with others. This is a time for students to try to clear up their own misconceptions through discourse with teacher facilitation.

TASK DESCRIPTION, DEVELOPMENT AND DISCUSSION:

This task is designed to reinforce student understanding of angle relationships when lines intersect and when a transversal crosses parallel lines. Using geometric properties of intersecting and parallel lines to establish and reinforce algebraic relationships is an almost limitless and rich source of problems for student practice and connections between mathematical concepts.

Task Description

Part 1:

In this task students are presented with a billiards scenario to win the game:

To win the game you need to sink the #8 black ball but if you hit the #3 red ball you will foul and could lose the game. You need to make the perfect shot! Illustrate your shot and prove it will go in using geometric reasoning and understanding of angles.

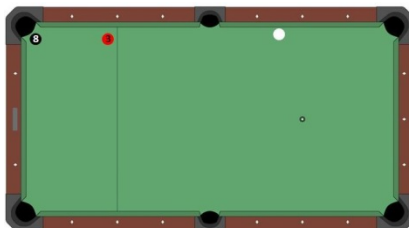

This task has a low entry point however some of the rules of billiards may need to be explained or reviewed before proceeding.

- Using the white ball, the player must sink the black ball in the pocket.
- The red ball cannot be jumped
- The white ball is not allowed to make contact with the red ball until after the black ball has been hit.

The majority of students will immediately recognize that they need to make a bank shot (*a bank shot is when the white ball or a colored ball is purposefully hit of the side of the table*). Students will pick a point along a wall but how can they prove that their shot is going to be a successful one.

If students are having a difficult time proving that their shot will be successfully have them use a ball and roll it off a wall to explore the angles into the wall and the angles off the wall. Students should arrive to the conclusion that will help them arrive to the conjecture that the angle into the wall is equal to the angle off the wall. After this conjecture is realized students may want to adjust the position of their bank shot.

Extension:

- Most students will probably only make one bank shot to sink the black ball. If that is the case ask the students if they would be able to make a double or triple bank shot.

Part 2:

Show students the video about the 2 ways to successfully make a bank shot <http://vimeo.com/98829715>. Ask students to use what they know to prove how the *midpoint bank shot* works by creating their own scenario.

An example:

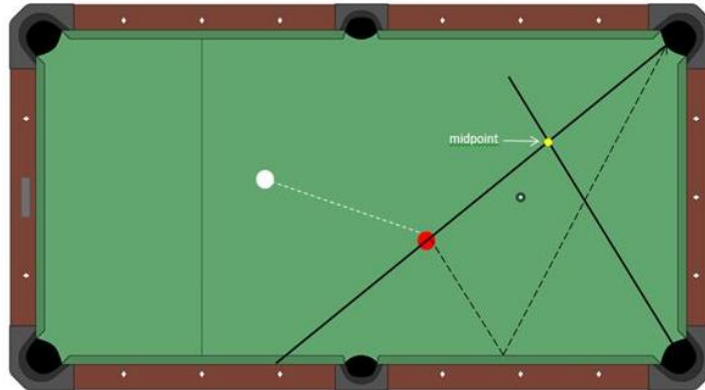

For The Win!

Name: _____

Part 1:

To win the game you need to sink the #8 black ball but if you hit the #3 red ball you will scratch and lose the game. You need to make the perfect shot! Illustrate your shot and prove it will go in using geometric reasoning and understanding of angles.

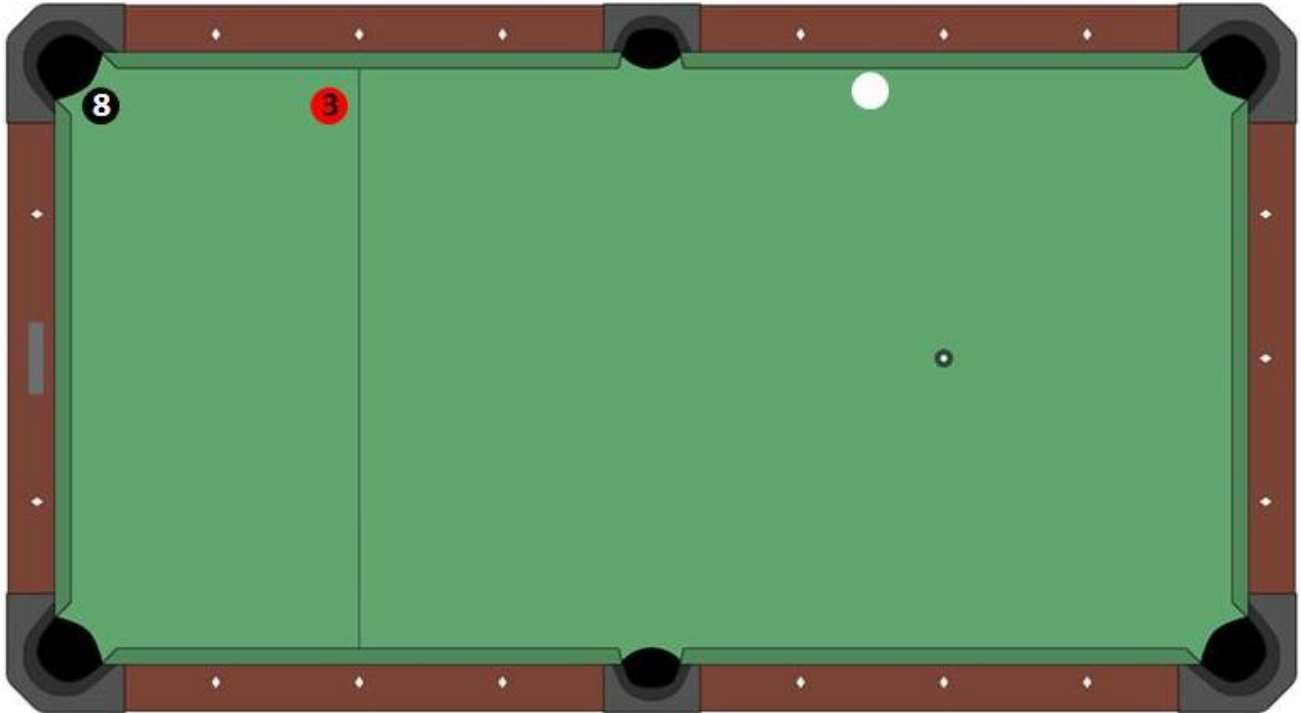

Explain your reasoning:

For The Win!

Name: _____

Part 2:

Watch the video: <http://vimeo.com/98829715>

Using the pool table below construct an example of how the *midpoint bank shot* works using the description presented by the professional player.

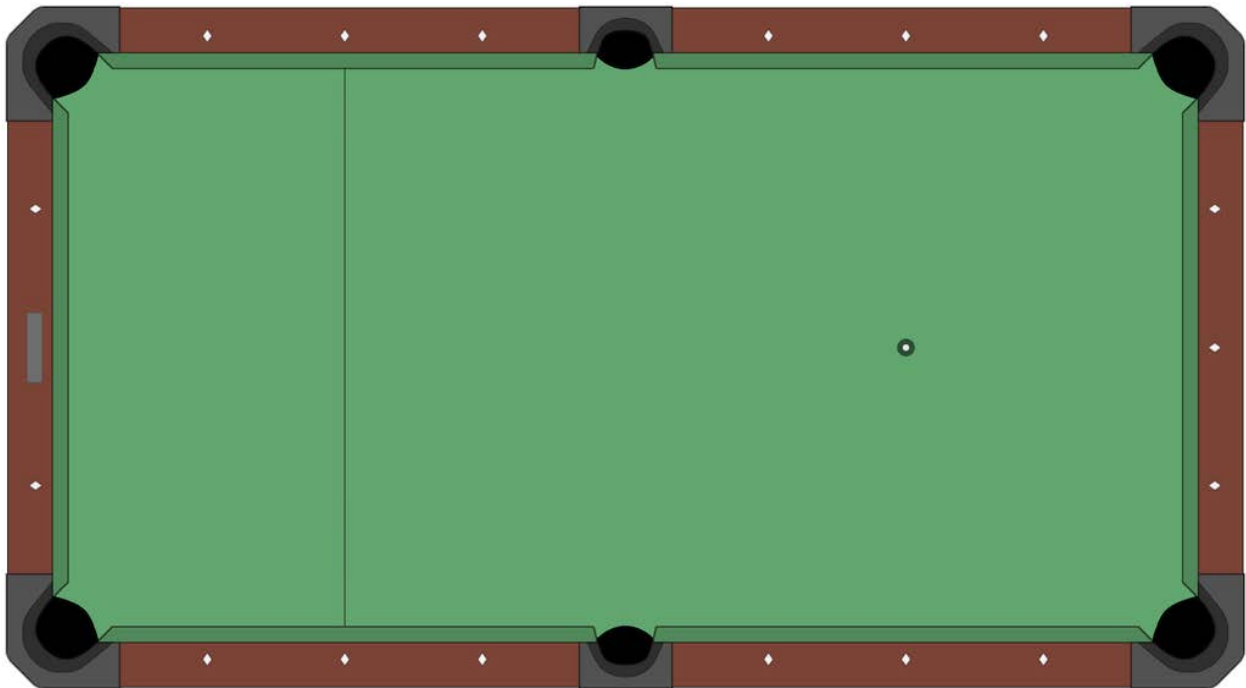

Explain why the *midpoint bank shot* works:

Window “Pain”

[Back to Task Table](#)

In this task, students will reinforce understanding of angle relationships of intersecting and parallel/transversal lines.

STANDARDS FOR MATHEMATICAL CONTENT:

MGSE8.G.5 Use informal arguments to establish facts about the angle sum and exterior angle of triangles, about the angles created when parallel lines are cut by a transversal, and the angle-angle criterion for similarity of triangles. *For example, arrange three copies of the same triangle so that the three angles appear to form a line, and give an argument in terms of transversals why this is so.*

STANDARDS FOR MATHEMATICAL PRACTICE:

This task uses all of the practices with emphasis on:

1. Make sense of problems and persevere in solving them.
2. Reason abstractly and quantitatively.
3. Construct viable arguments and critique the reasoning of others.
4. Model with mathematics.
5. Use appropriate tools strategically.
6. Attend to precision.
7. Look for and make use of structure.

BACKGROUND KNOWLEDGE/TEACHER NOTES:

After students investigate parallel lines and the angle pairs formed when these lines are cut by a transversal (as in the previous tasks), it’s important that they have some purposeful practice and time to discuss their sense making with others. This is a time for students to try to clear up their own misconceptions through discourse with teacher facilitation.

COMMON MISCONCEPTIONS:

- *Students tend to have trouble recalling that lines measure 180 degrees.*
- *Some student may require a review of writing and solving equations.*

ESSENTIAL QUESTIONS:

- How can I be certain whether lines are parallel, perpendicular, or skew lines?
- Why do I always get a special angle relationship when any two lines intersect?
- When I draw a transversal through parallel lines, what are the special angle and segment relationships that occur?

MATERIALS:

- Copy of the task

GROUPING:

- *Individual/Partner/Small Group*

TASK DESCRIPTION, DEVELOPMENT AND DISCUSSION:

This task is designed to reinforce student understanding of angle relationships when lines intersect and when a transversal crosses parallel lines. Using geometric properties of intersecting and parallel lines to establish and reinforce algebraic relationships is an almost limitless and rich source of problems for student practice and connections between mathematical concepts.

Have students use a MIRA™ or fold paper to verify line of symmetry.

DIFFERENTIATION:

Extension:

- Instruct students to draw a large triangle on graph paper using a ruler and cut the triangle out. Students should then label each angle (A, B, and C will suffice) and determine a way to prove that the angles in the triangle sum to 180 degrees. Students may view this website if they are having difficulty. <http://www.mathsisfun.com/proof180deg.html>

Intervention:

- Have students review angle relationships formed by a transversal through parallel lines. Don't feel that you need to have struggling students do Part 2. Group students in a way that promotes cooperative learning (pair less verbal students with more verbal students).

Georgia Department of Education
Georgia Standards of Excellence Framework
GSE Grade 8 • Unit 1



www.vloeberghs.com

Georgia Department of Education
Georgia Standards of Excellence Framework
GSE Grade 8 • Unit 1



www.vloeberghs.com

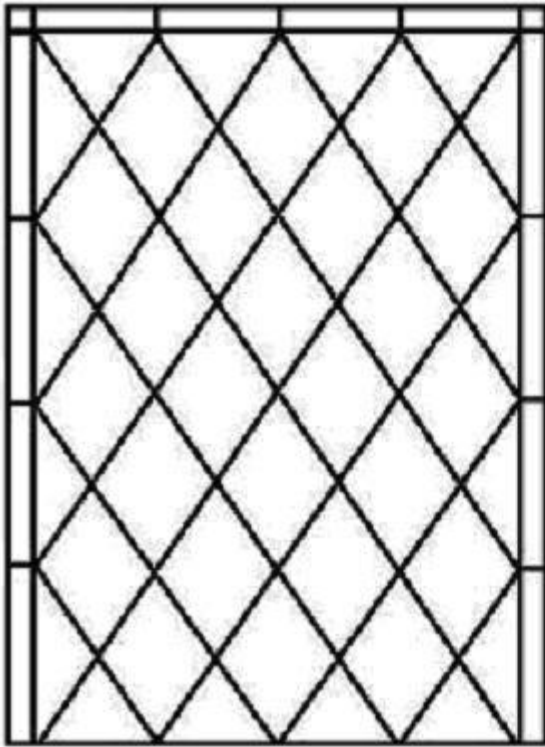

LEADED GLASS PANEL - DIAMOND

The most classic Tudor glazing pattern. Select glass type and color(s). This pattern looks great with an occasional pastel pane. This example has edge panes which are priced separately.

www.tudorartisans.com

Window “Pain”

Part 1:

Your best friend’s newest blog entry on FaceBook reads:

Last night was the worst night ever! I was playing ball in the street with my buds when, yes, you guessed it, I broke my neighbor’s front window. Every piece of glass in the window broke! Man, my Mom was soooooooooooooo mad at me! My neighbor was cool, but Mom is making me replace the window. Bummer!

It is a Tudor-style house with windows that look like the picture below.

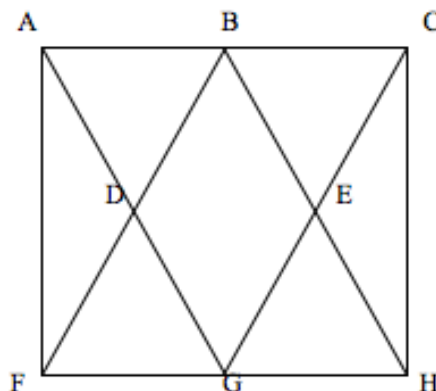

I went to the Clearview Window Company and showed them the picture above. They told me they could fix it. What was really weird was that the only measurements that the guy wanted were $\angle BAD$ (60°), $\angle BCE$ (60°), and \overline{AG} (28 inches).

I told him it was a standard rectangular window and that I had measured everything, but he told me not to worry because he could figure out the other measurements. It is going to cost me \$20 per square foot, so I need to figure out how to make some money real quick.

How did the window guy know all of the other measurements and how much is this going to cost me?

Because you are such a good best friend, you are going to reply to the blog by emailing the answers to the questions on the blog along with detailed explanations about how to find every angle measurement and the lengths of each edge of the glass pieces. You will also explain how to figure out the amount of money he will need.

Students may think this through in a variety of ways and still be mathematically correct.

Using the picture of the window with line intersections marked will make it easier to explain strategies used to answer the questions.

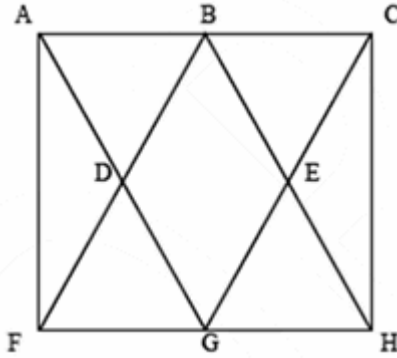

Knowing that $m\angle BAD = 60^\circ$ and $m\angle BCE = 60^\circ$ because they were given in the blog, it is possible to determine the measures of every other angle of every piece of glass in the window using thinking similar to the following comments.

- $m\angle AGC = 60^\circ \Leftarrow 180^\circ$ in $\triangle ACG$.
- $m\angle ADB = 60^\circ \Leftarrow$ corresponds to $\angle DGE$.
- $m\angle FDG = 60^\circ \Leftarrow$ vertical to $\angle ADB$.
- $m\angle ABD = 60^\circ \Leftarrow 180^\circ$ in $\triangle ABD$.
- $m\angle DBE = 60^\circ \Leftarrow$ corresponds to $\angle FDG$.
- $m\angle EBC = 60^\circ \Leftarrow$ supplementary to $\angle ABE$.
- $m\angle BEC = 60^\circ \Leftarrow 180^\circ$ in $\triangle BCE$.
- $m\angle GEH = 60^\circ \Leftarrow$ vertical to $\angle BEC$.
- $m\angle AGF = 60^\circ \Leftarrow$ alternate interior to $\angle BAG$.
- $m\angle CGH = 60^\circ \Leftarrow$ alternate interior to $\angle CBH$.
- $m\angle DFG = 60^\circ \Leftarrow 180^\circ$ in $\triangle DFG$.
- $m\angle EGH = 60^\circ \Leftarrow 180^\circ$ in $\triangle EGH$.
- $m\angle ADF = 120^\circ \Leftarrow$ supplementary to $\angle ADB$.
- $m\angle BDG = 120^\circ \Leftarrow$ supplementary to $\angle ADB$.
- $m\angle BEG = 120^\circ \Leftarrow$ supplementary to $\angle GEH$.
- $m\angle CEH = 120^\circ \Leftarrow$ supplementary to $\angle GEH$.
- $m\angle FAD = 30^\circ \Leftarrow$ complementary to $\angle BAD$.
- $m\angle AFD = 30^\circ \Leftarrow$ complementary to $\angle DFG$.
- $m\angle ECH = 30^\circ \Leftarrow$ complementary to $\angle BCE$.
- $m\angle CHE = 30^\circ \Leftarrow$ complementary to $\angle GHE$.

All angle measurements for each piece of glass have been found as shown below.

Georgia Department of Education
 Georgia Standards of Excellence Framework
 GSE Grade 8 • Unit 1

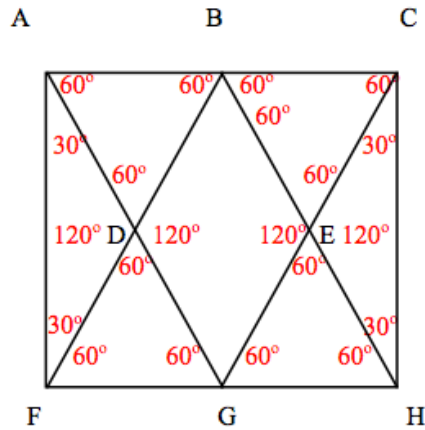

Looking at $\triangle ADF$ we know that $\overline{AD} \cong \overline{DG}$ because the base angles are congruent so the triangle is isosceles.

Observing $\triangle ABD$ and $\triangle DFG$ we see that they are equilateral and all of their sides must be the same length. Therefore $\overline{AB} \cong \overline{AD} \cong \overline{BD}$ and $\overline{FD} \cong \overline{FG} \cong \overline{DG}$. Since \overline{AG} is 28 inches long, this forces all six of the lengths mentioned to be 14 inches long. The same argument can be made for the other side of the window to determine that $\overline{BE} \cong \overline{BC} \cong \overline{CE}$ and $\overline{GE} \cong \overline{GH} \cong \overline{EH}$.

The only missing sides are \overline{AF} and \overline{CH} . To determine the length of \overline{AF} , we may look at the right $\triangle AFG$ and use the Pythagorean Theorem (Extension /Differentiation activity).

$$\begin{aligned}
 AF^2 + FG^2 &= AG^2 \\
 AF^2 + 14^2 &= 28^2 && \text{by substitution} \\
 AF^2 + 196 &= 784 && \text{by squaring} \\
 AF^2 &= 588 && \text{subtracting 196 from both sides of the equation} \\
 \sqrt{AF^2} &= \sqrt{588} && \text{taking the square root of each side of the equation} \\
 AF &\approx 24.25 \text{ in.}
 \end{aligned}$$

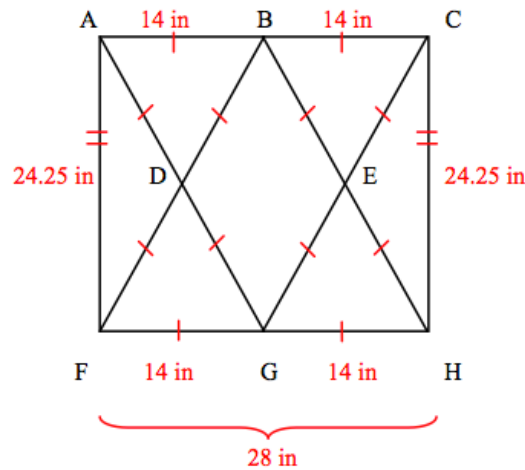

To determine how much it will cost to replace the window at \$20 per square foot, the area of the window is needed.

$$A = bh$$
$$A \approx (28)(24.25)in.^2$$
$$A \approx 679 in.^2$$

Knowing that there are $144 in.^2$ in each square foot, there are $679 \div 144 \approx 4.72$ square feet of glass to be ordered.

Thus, the cost will be $(4.72)(20) = \$94.40$ not including any tax or shipping costs that may apply.

Part 2:

(Two weeks later)

You just received a text message from your best friend and were told that the order of glass had been delivered to the house by Package Express. Unfortunately, one of the pieces was broken upon arrival and needed to be reordered by Clearview Window Company. Because you are very curious, you think it would be a good idea to determine the probability of each piece of glass being the one broken.

Write another email to your friend that explains the probabilities and how you determined them.

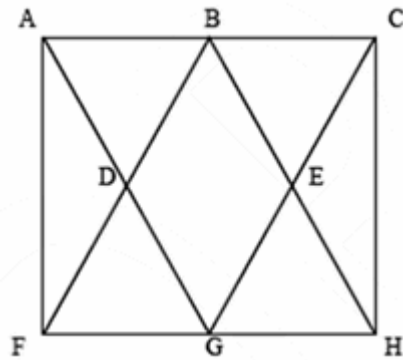

In finding this probability, there may be a few students that actually determine the area of each shape and use the ratio of those areas to the area of the window. This would be correct mathematical thinking. However, most of the students should know that $\triangle ADF$, $\triangle BCE$, $\triangle FDG$, and $\triangle GEH$ are congruent because all six of their corresponding parts are congruent.

They should notice that $\square BDGE$ has the same area as two triangles that are congruent to $\triangle ABD$. In addition, $\triangle ADF$ and $\triangle CEH$ are each half of the area of $\square BDGE$, and have the same area as the triangles congruent to $\triangle ABD$. They are congruent because all six of their corresponding parts are congruent.

Therefore, if $x =$ the area of $\triangle ABD$, the area of the window would be $4(\text{area of } \triangle ABD) + 2(\text{area of } \triangle ADF) +$ the area of $\square BDGE$, or $4x + 2x + 2x = 8x$.

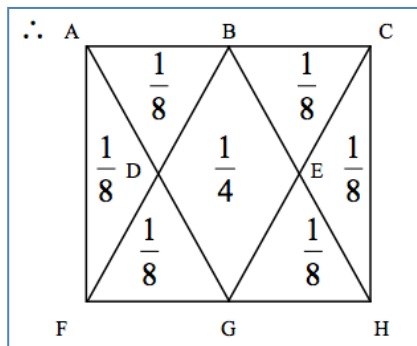

Window “Pain”

Part 1:

Your best friend’s newest blog entry on FaceBook reads:

Last night was the worst night ever! I was playing ball in the street with my buds when, yes, you guessed it, I broke my neighbor’s front window. Every piece of glass in the window broke! Man, my Mom was soooooooooooooo mad at me! My neighbor was cool, but Mom is making me replace the window. Bummer!

It is a Tudor-style house with windows that look like the picture below.

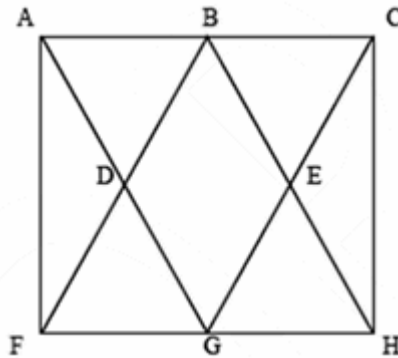

I went to the Clearview Window Company and showed them the picture above. They told me they could fix it. What was really weird was that the only measurements that the guy wanted were $\angle BAD$ (60°), $\angle BCE$ (60°), and \overline{AG} (28 inches).

I told him it was a standard rectangular window and that I had measured everything, but he told me not to worry because he could figure out the other measurements. It is going to cost me \$20 per square foot, so I need to figure out how to make some money real quick.

How did the window guy know all of the other measurements and how much is this going to cost me?

Because you are such a good best friend, you are going to reply to the blog by emailing the answers to the questions on the blog along with detailed explanations about how to find every angle measurement and the lengths of each edge of the glass pieces. You will also explain how to figure out the amount of money he will need.

Part 2:

(Two weeks later)

You just received a text message from your best friend and were told that the order of glass had been delivered to the house by Package Express. Unfortunately, one of the pieces was broken upon arrival and needed to be reordered by Clearview Window Company. Because you are very curious, you think it would be a good idea to determine the probability of each piece of glass being the one broken.

Write another email to your friend that explains the probabilities and how you determined them.

Culminating Task: Sheldon’s Shelving Suggestions

[Back to Task Table](#)

In this task, students will reinforce understanding of angle relationships of intersecting and parallel/transversal lines.

STANDARDS FOR MATHEMATICAL CONTENT:

MGSE8.G.2 Understand that a two-dimensional figure is congruent to another if the second can be obtained from the first by a sequence of rotations, reflections, and translations; given two congruent figures, describe a sequence that exhibits the congruence between them.

MGSE8.G.4 Understand that a two-dimensional figure is similar to another if the second can be obtained from the first by a sequence of rotations, reflections, translations, and dilations; given two similar two-dimensional figures, describe a sequence that exhibits the similarity between them.

MGSE8.G.5 Use informal arguments to establish facts about the angle sum and exterior angle of triangles, about the angles created when parallel lines are cut by a transversal, and the angle-angle criterion for similarity of triangles. *For example, arrange three copies of the same triangle so that the three angles appear to form a line, and give an argument in terms of transversals why this is so.*

STANDARDS FOR MATHEMATICAL PRACTICE:

This task uses all of the practices with emphasis on:

1. Make sense of problems and persevere in solving them.
2. Reason abstractly and quantitatively.
3. Construct viable arguments and critique the reasoning of others.
4. Model with mathematics.
5. Use appropriate tools strategically.
6. Attend to precision.
7. Look for and make use of structure.

BACKGROUND KNOWLEDGE/TEACHER NOTES:

It may be helpful to check students’ understanding of the new vocabulary: similar, congruent, reflections, translations, dilations and rotations as well as find out what they “know” about the effects these transformations have on points and figures in the plane.

In order for students to be successful, students should be confident in their understandings of the following standards:

[MGSE5.G.1](#) [MGSE5.G.2](#) [MGSE6.G.3](#) [MGSE7.G.1](#)

COMMON MISCONCEPTIONS:

- *Students tend to have trouble recalling that lines measure 180 degrees.*
- *Some student may require a review of writing and solving equations.*
- *Students will need multiple opportunities to explore the transformation of figures so that they can appreciate that points stay the same distance apart and lines stay at the same angle after they have been rotated, reflected, and/or translated.*

ESSENTIAL QUESTIONS:

- Why do I always get a special angle relationship when any two lines intersect?
- When I draw a transversal through parallel lines, what are the special angle and segment relationships that occur?

MATERIALS:

- colored pencils
- layout handout
- paper strips

GROUPING:

- *Individual/Partner/Small Group*

TASK DESCRIPTION, DEVELOPMENT AND DISCUSSION:

Throughout this task, there are multiple ways for these ideas to be explained. Teachers should be open to alternative explanations from students while helping them gain an appreciation for elegant and efficient approaches. Above all, this is a task for which there are **many** different valid solutions. Students should gain a clear understanding of the fact that most problems (even those with only one final answer) have multiple, creative ways in which they could be solved.

Students should be encouraged to label any needed points on the diagram to help support their reasoning their particular solution.

Have students use a MIRA™ or fold paper to verify line of symmetry.

DIFFERENTIATION:

Extension:

- Students will investigate parallel lines cut by a transversal at this Lesson website:
<http://www.mathwarehouse.com/geometry/angle/parallel-lines-cut-transversal.php>
- Students can then practice with challenging problems in the Practice website:
<http://www.mathwarehouse.com/geometry/angle/parallel-lines-transversal-practice.php>

Intervention:

- Prompt struggling students by asking guiding questions. Group students in a way that promotes cooperative learning.

Sheldon’s Shelving Suggestions

Sheldon’s Construction Company has been hired by a famous artist, Trans Versal, to do some interior construction in his studio. Mr. Versal wants Sheldon to install a series of horizontal shelves on a brick wall in the studio. The bricks in every wall Sheldon had ever seen had been laid horizontally, so he left his level at home when he went to Trans’ studio Monday morning. When Sheldon arrived, he noticed that Trans’ art defied convention even in the construction of his wall – it had been laid at an angle, a portion of which is shown below. The long horizontal rectangle is the base molding along the floor and the letters refer to specific corners of the bricks. Assume the bricks in the wall continue to the left, right, and up from those shown in the picture.

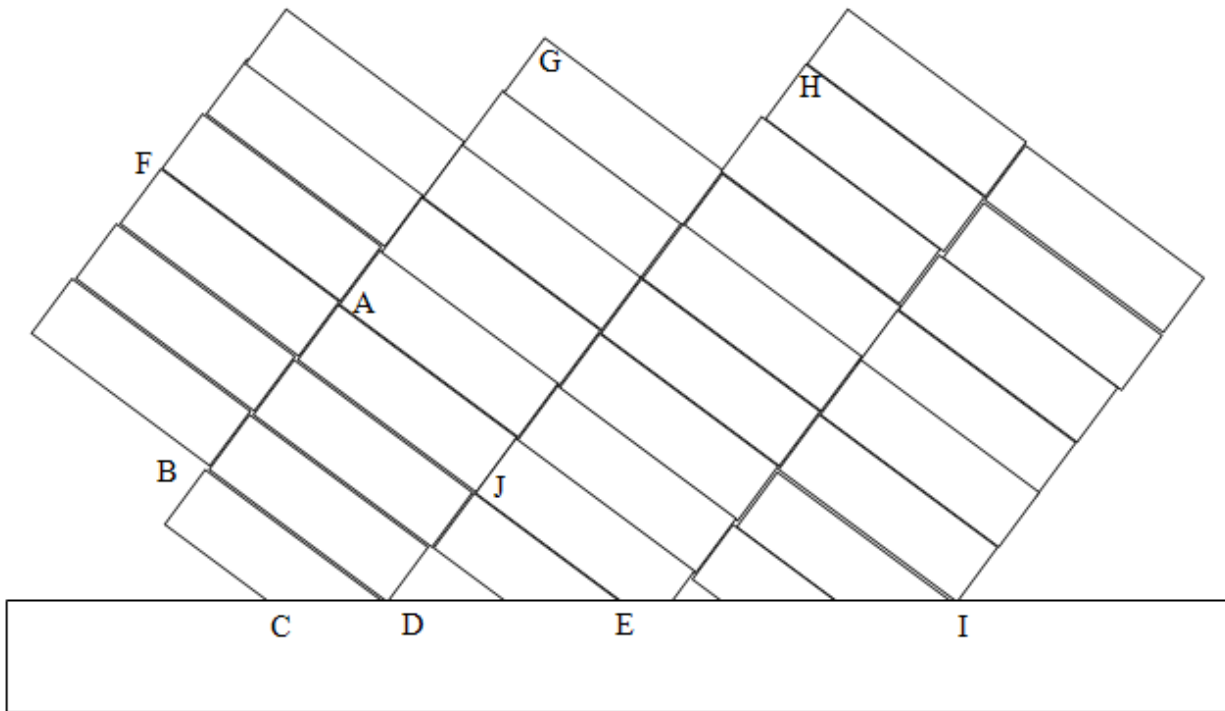

Trans Versal wanted the left end of the 12-foot shelf to begin at point A. Since Sheldon did not have his level, he knew he had to find another way to guarantee that the shelf he installed was perfectly horizontal. Sheldon asked his employees to suggest ways to accomplish this, and he got several ideas.

Tom didn't have a protractor to measure any angles, but was sure that if he cut a block of wood so that it was congruent to $\triangle JDE$, then he could place one of the vertices of the block at point A and draw a line parallel to the floor. Explain how and why Tom's block works.

Sandra thought she could use a block cut congruent to a different triangle. Find a way to do this and explain why it works.

Are there methods that don't use congruent triangles to find the locations of parallel lines? Be creative, but be sure to explain how you are certain that your technique works. Which of the techniques did you like best? Which would be easiest to use? Explain your responses.

Understand that you may label any additional points on the diagram as needed.

Solution

It may even help students visualize this problem if diagonal "bricks" are taped to different walls in the classroom so that students can perform their work on an actual wall. Students could work in groups of four, each assuming the role of one of the employees mentioned. Each student would then need to explain (and write!) his or her solution for the entire group.

Tom – Tom is correct. While explanations can vary, one sample follows: If the block congruent to $\triangle JDE$ is translated so that point D is on point A and point J on \overline{AG} above point D, then \overline{DE} will be parallel to the floor, and therefore horizontal. NOTE: Some students may see this easily, but others will need to cut out a paper triangle congruent to $\triangle JDE$ and physically place the triangle as described above. Teachers should encourage this use of manipulatives, possibly guiding students to choose this approach on their own rather than directly instructing them to do so.

In essence, this is an application of the fact that corresponding angles are congruent when they are created by a transversal crossing parallel lines. Many students will benefit from drawing auxiliary lines to see this.

An alternative approach is to place point D again on point A, but this time with point J on line \overline{AG} below point D. This will require rotating the triangle, but \overline{DE} will again be parallel to the floor, this time via alternate interior angles.

Sandra is also correct. $\angle JDC$ is supplementary to $\angle JDE$, the angle in $\triangle JDE$ used to establish parallel lines for Tom's approach. The same two types of transformations used above will work on $\triangle JDC$ (or any other triangle incorporating an angle congruent to $\angle JDC$), again using corresponding or alternate interior angles to establish a parallel line, depending on the transformation.

Three possibilities for alternative methods follow. These may not be the only possibilities students may discover, but most will likely derive some form of these two approaches. While other block counts work, one approach would be to notice that points D and I both correspond to corners of bricks adjacent to the floor molding. Therefore line \overline{DE} must be horizontal. Starting at point D, one could move along the seams between bricks by counting 5 short bricks up and to the right, and then 2 long bricks down and to the right to end up at point I. Similarly, when Toni starts at point A, counts 5 short bricks up and to the right, and then 2 long bricks down and to the right, the resulting brick corner when connected with point A will create a line segment parallel to line \overline{DE} and the floor. This is exactly the same idea as slope, but on an unfamiliar and differently-oriented coordinate system. If you think about the stair-stepping approach students often use to plot additional points on a line given an initial point and the slope of the line, you should see that this is exact same type of movement, only along diagonals.

There are also a few ways to use the constant distance between lines. One method could be to lay an uncut piece of paper with one edge along the floor molding positioned so that point A is along one edge of the paper. (On the construction site, this would be done with a board.) Then, the position of A is marked on the paper and a cut is made in the paper perpendicular to the edge adjacent to A. Since the edge initially perpendicular to A is now perpendicular to both the new cut and the edge along the floor molding, the cut side and the molding must be parallel, making the cut side horizontal. Now slide the paper (or board) down the floor molding and mark any other point on the wall adjacent to the cut side of the paper (board). Connecting this new point to point A will create a horizontal line.

A third approach would be to use the ancient technology of plumb lines. In brief, if a string with a weight attached to one end is held steady so that the weight hangs freely, then the string will point directly toward the center of the earth and will be therefore, perpendicular to any horizontal line. A student can create a plumb line by tying a pencil or some other small weight to the end of a string. If the string is held loosely on the wall at point A and the weight is allowed to descend until the instant it touches the floor, then the plumb line will be perpendicular to the floor and its length is the distance between the floor and the desired shelf. Before moving the string, mark the location of point A on the string. Now, a student can move to another point along the wall, allow the weight to barely touch the floor as before, and mark the point on the wall adjacent to the marked spot on the string. The line formed by this point on the wall and point A must be horizontal.

All of the methods described above involve some type of measurement transfer from one point to another along the wall. Other arguments are also possible, including some that make use of the Pythagorean Theorem (Extension/Differentiation Activity). Such an approach would require a measurement transfer, but is not what most students would conceive.

Encourage student creativity, and showcase the different solutions students develop. Post-activity debriefing discussions should discuss the advantages and disadvantages of the different techniques. Ultimately, even if one approach is not the shortest approach, but it makes the most sense to a particular student, then that approach is probably best for that student even if it isn't the most mathematically elegant. Nevertheless, teachers should insist that students fairly evaluate the merits of every approach and give each technique a reasonable attempt.

Optional

This task can be adapted to bookshelves. Please refer to the pictures.



mysweetsavannah.blogspot.com

Georgia Department of Education
Georgia Standards of Excellence Framework
GSE Grade 8 • Unit 1



www.evadesigns.com

Culminating Task: Sheldon's Shelving Suggestions

Sheldon's Construction Company has been hired by a famous artist, Trans Versal, to do some interior construction in his studio. Mr. Versal wants Sheldon to install a series of horizontal shelves on a brick wall in the studio. The bricks in every wall Sheldon had ever seen had been laid horizontally, so he left his level at home when he went to Trans' studio Monday morning. When Sheldon arrived, he noticed that Trans' art defied convention even in the construction of his wall – it had been laid at an angle, a portion of which is shown below. The long horizontal rectangle is the base molding along the floor and the letters refer to specific corners of the bricks. Assume the bricks in the wall continue to the left, right, and up from those shown in the picture.

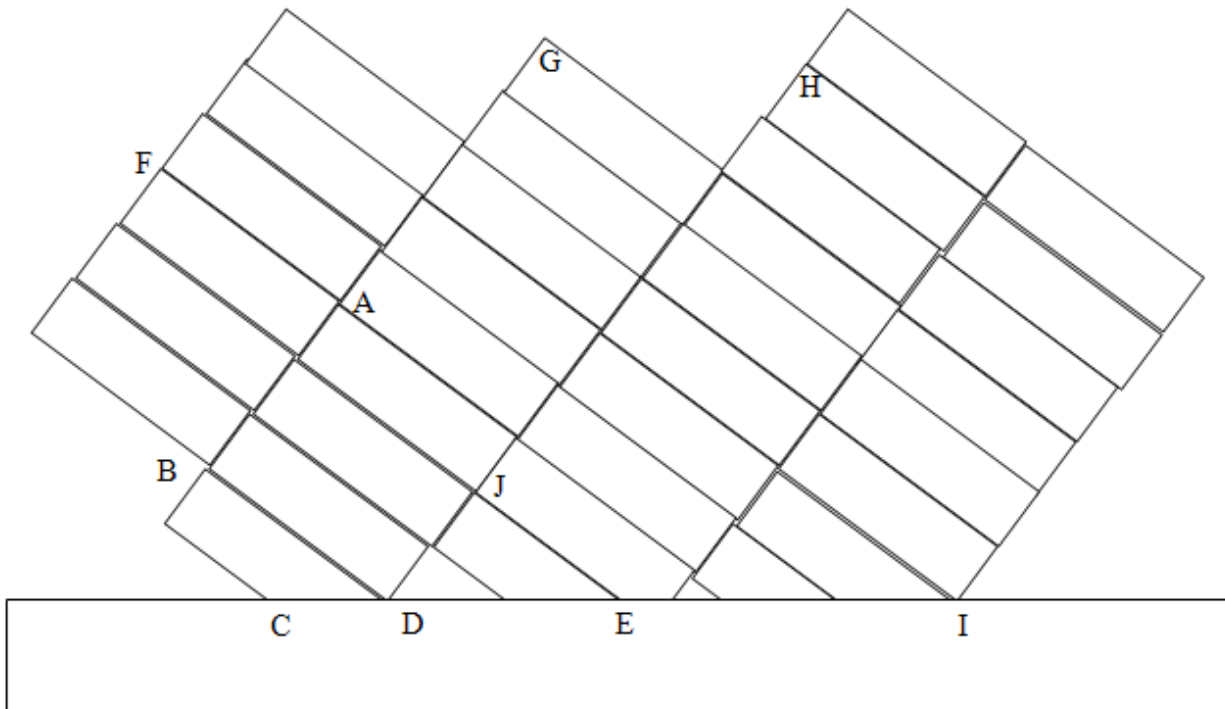

Trans Versal wanted the left end of the 12-foot shelf to begin at point A. Since Sheldon did not have his level, he knew he had to find another way to guarantee that the shelf he installed was perfectly horizontal. Sheldon asked his employees to suggest ways to accomplish this, and he got several ideas.

Tom didn't have a protractor to measure any angles, but was sure that if he cut a block of wood so that it was congruent to $\triangle JDE$, then he could place one of the vertices of the block at point A and draw a line parallel to the floor. Explain how and why Tom's block works.

Sandra thought she could use a block cut congruent to a different triangle. Find a way to do this and explain why it works.

Georgia Department of Education
Georgia Standards of Excellence Framework
GSE Grade 8 • Unit 1

Are there methods that don't use congruent triangles to find the locations of parallel lines? Be creative, but be sure to explain how you are certain that your technique works. Which of the techniques did you like best? Which would be easiest to use? Explain your responses.

Understand that you may label any additional points on the diagram as needed.

Technology Resources

[Back to Task Table](#)

MGSE8.G.1 Verify experimentally the congruence properties of rotations, reflections, and translations: lines are taken to lines and line segments to line segments of the same length; angles are taken to angles of the same measure; parallel lines are taken to parallel lines.

<https://www.illustrativemathematics.org/content-standards/8/G/A/1>
<http://nzmaths.co.nz/transformation-units-work>

MGSE8.G.2 Understand that a two-dimensional figure is congruent to another if the second can be obtained from the first by a sequence of rotations, reflections, and translations; given two congruent figures, describe a sequence that exhibits the congruence between them.

<https://www.illustrativemathematics.org/content-standards/8/G/A/2>
<http://nzmaths.co.nz/transformation-units-work>

MGSE8.G.3 Describe the effect of dilations, translations, rotations, and reflections on two-dimensional figures using coordinates.

<https://www.illustrativemathematics.org/content-standards/8/G/A/3>
<http://nzmaths.co.nz/transformation-units-work>

MGSE8.G.4 Understand that a two-dimensional figure is similar to another if the second can be obtained from the first by a sequence of rotations, reflections, translations, and dilations; given two similar two-dimensional figures, describe a sequence that exhibits the similarity between them.

<https://www.illustrativemathematics.org/content-standards/8/G/A/4>
<http://nzmaths.co.nz/transformation-units-work>

MGSE8.G.5 Use informal arguments to establish facts about the angle sum and exterior angle of triangles, about the angles created when parallel lines are cut by a transversal, and the angle-angle criterion for similarity of triangles. *For example, arrange three copies of the same triangle so that the three angles appear to form a line, and give an argument in terms of transversals why this is so.*

<https://www.illustrativemathematics.org/content-standards/8/G/A/5>
<http://nzmaths.co.nz/resource/angles-parallel-lines-and-polygons>